

ASM

Asynchronous Spindle Motors

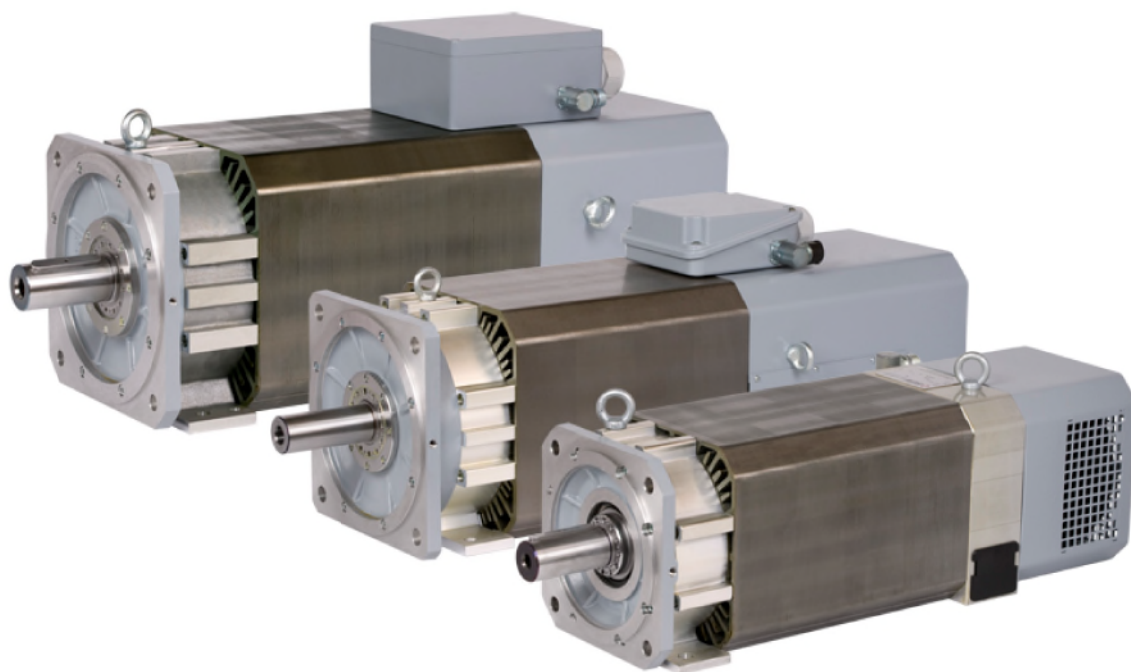

SEM Limited
Faraday Way
Orpington, Kent
BR5 3QT
United Kingdom

Tel: +44 (0)1689 884700
Fax: +44 (0)1689 884884
Email: sales@sem.co.uk
Web: www.sem.co.uk

Asynchronous Motors

ASM Overview

General technical information

Speed measurement

An integrated rotary encoder from HEIDENHAIN measures the shaft speed.

- Motors with a solid shaft are fitted with an ERN1381 encoder with 1024 lines.
- Motors with a hollow shaft are fitted with an ERM280 encoder with 600 lines.

Specifications

The specifications and the performance curves apply when motors are mounted without thermal insulation. All ratings apply with a maximum temperature rise of 105K on the winding based on a maximum ambient temperature of 40°C. If the motor is mounted so that it is thermally insulated, it is necessary to reduce the motor torque in order to avoid thermal overloading of the motor.

Shaft bearing

SEM asynchronous motors are fitted with maintenance-free bearings. The shaft bearings used on **motors with solid shaft** are available as either standard or high specification spindle bearings. When using spindle bearings the motor can withstand greater radial forces and allowing for higher spindle speeds. Motors with spindle bearing are slightly longer.

Hollow-shaft motors are always fitted with the high specification spindle bearings.

Mechanical life

The service life of the bearings depends on the shaft load and the average shaft speed (contact SEM for further details).

The nominal bearing service life is 10000 hours - this depends on the specific motor, the maximum shaft load and the average motor shaft speed.

Shaft end

ASM asynchronous motors from SEM have a shaft extension end as per DIN 748-1. The solid-shaft motors have a centering hole as per DIN 332-DR.

The standard versions of the asynchronous motor have a plain shaft (without keyway and feather key). Upon request the motors are available with keyway and feather key as per DIN 6885-1.

Feather key:

ASM 200: AS 10 x 8 x 70

ASM 260: AS 12 x 8 x 90

ASM 320: AS 16 x 10 x 90

Precision balancing

Balancing of ASM asynchronous motors from SEM can be done at any time.

Hollow-shaft motors

The ASM 200 UH and ASM 260 xH motors with hollow shaft are suited for direct mounting to mechanical spindles. The hollow shaft permits you to convey coolant to tools with inner cooling.

The coolant is introduced at the rear of the motor through a rotating manifold (e.g. from Deublin, order no.: 1109-020-188). The shaft end is designed for this.

Mechanical data

Dimensions IM B35 (for securing by flange/base) as per EN 60 034-7

Flange: Dimensions as per DIN 42 948 and IEC 72

Protection as per EN 60 529: IP 54

Vibration severity

Grade SR (external precision balancing possible)

(IEC 60 034-14)

Thermal variables

Separate cooling via integrated fan
Temperature monitoring with KTY 84-130 thermistor in the stator winding

Thermal class F

Asynchronous motors with solid shaft	Rated power output	Rated speed	Max. speed		Rated torque	Rated current			
			Standard bearing	Spindle bearing					
ASM 200M	5.5 kW	1500 min ⁻¹	9000 min ⁻¹	12000 min ⁻¹	35.0 Nm	18.0 A			
ASM 200L	7.5 kW	1500 min ⁻¹	9000 min ⁻¹	12000 min ⁻¹	47.8 Nm	20.1 A			
ASM 200U	10.0 kW	1500 min ⁻¹	9000 min ⁻¹	12000 min ⁻¹	63.7 Nm	25.0 A			
ASM 260M	15.0 kW	1500 min ⁻¹	8000 min ⁻¹	10000 min ⁻¹	95.5 Nm	35.0 A			
ASM 260L	20.0 kW	1500 min ⁻¹	8000 min ⁻¹	10000 min ⁻¹	127.3 Nm	46.0 A			
ASM 260U	24.0 kW	1500 min ⁻¹	8000 min ⁻¹	10000 min ⁻¹	152.8 Nm	58.0 A			
ASM 260W	12.0 kW	750 min ⁻¹	8000 min ⁻¹	10000 min ⁻¹	152.8 Nm	29.0 A			
ASM 320M	32.0 kW	1500 min ⁻¹	8000 min ⁻¹	10000 min ⁻¹	203.7 Nm	77.5 A			
ASM 320L	40.0 kW	1500 min ⁻¹	8000 min ⁻¹	10000 min ⁻¹	254.6 Nm	99.0 A			

Asynchronous motors with hollow shaft	Rated power output	Rated speed	Max. speed		Rated torque	Rated current			
			Standard bearing	Spindle bearing					
ASM 200UH	10.0 kW	1500 min ⁻¹	–	12000 min ⁻¹ / 15000 min ⁻¹	63.7 Nm	25.0 A			
ASM 260MH	15.0 kW	1500 min ⁻¹	–	12000 min ⁻¹	96.0 Nm	35.0 A			
ASM 260LH	20.0 kW	1500 min ⁻¹	–	12000 min ⁻¹	128.0 Nm	46.0 A			
ASM 260UH	22.0 kW	1500 min ⁻¹	–	10000 min ⁻¹ / 12000 min ⁻¹	140.0 Nm	54.0 A			

Asynchronous Motors with Solid Shaft

ASM 200 Series

Spindle motors with 2 pole pairs
 Rated power output 5.5 kW to 10 kW
 Choice of standard or high specification spindle bearing

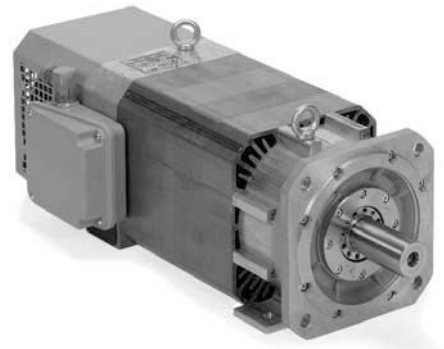

Motor	ASM 200M	ASM 200L	ASM 200U
Rated voltage U_N	250 V	305 V	330 V
Rated power output P_N	5.5 kW	7.5 kW	10.0 kW
Rated shaft speed n_N	1500 min ⁻¹		
Rated torque M_N (105 K)	35.0 Nm	47.8 Nm	63.7 Nm
Rated current I_N (105 K)	18.0 A	20.1 A	25.0 A
Efficiency	0.85		
Max. speed n_{max} ¹⁾ Standard bearing Spindle bearing	9000 min ⁻¹ 12000 min ⁻¹		
Max. current I_{max}	33 A	36 A	44 A
Weight m	51 kg	68 kg	83 kg
Rotor inertia J	245 kgcm ²	353 kgcm ²	405 kgcm ²
Protection	IP 54		
Fan Rated voltage U_L Rated current I_L Frequency f_L	3 × 400 V 0.2 A 50 Hz/60 Hz		
ID Motor with standard bearing Motor with spindle bearing			

¹⁾ The max. speed depends on the motor's application conditions, such as the shaft load
 (Contact SEM for further information).

Rotatable connections

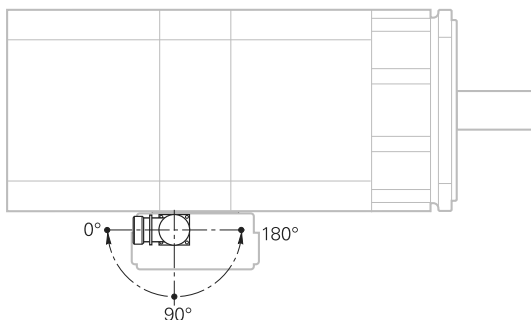

Dimensions in mm



Tolerancing ISO 8015
 ISO 2768 - m H
 < 6 mm: ±0.2 mm

ASM 200M

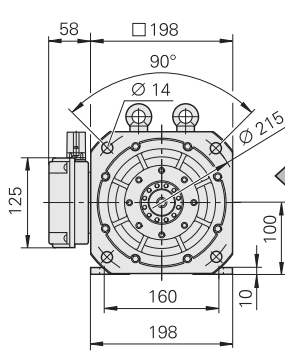

With standard bearing

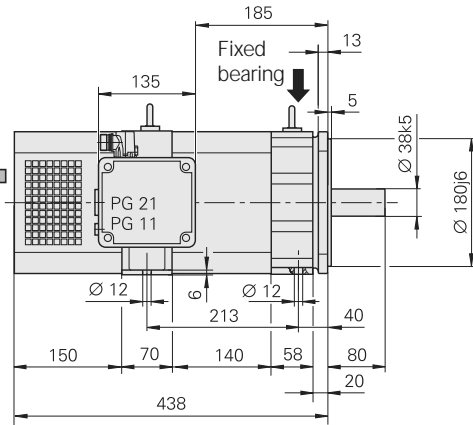

With high speed spindle bearing

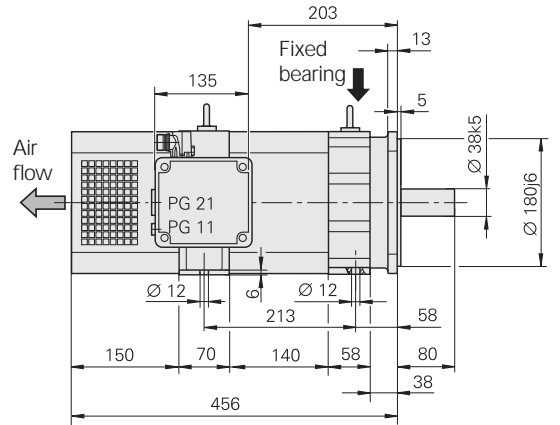

ASM 200L

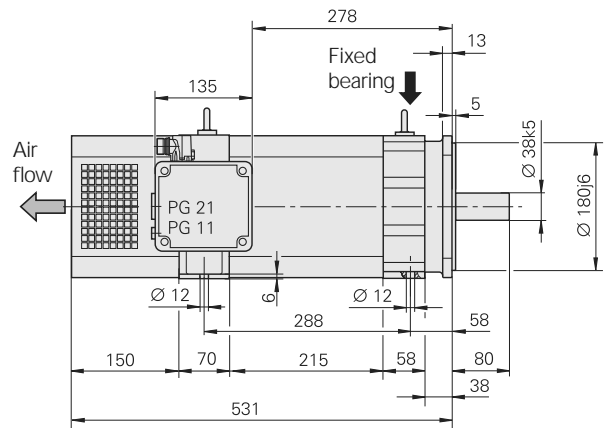
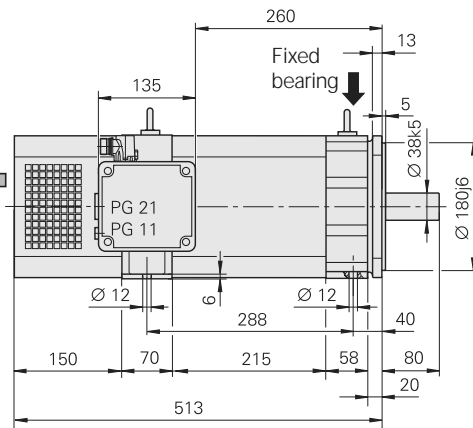
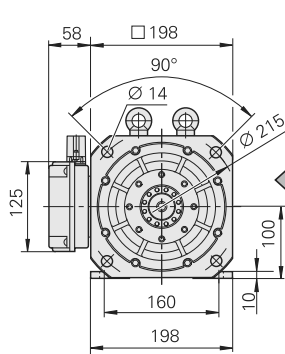

ASM 200U

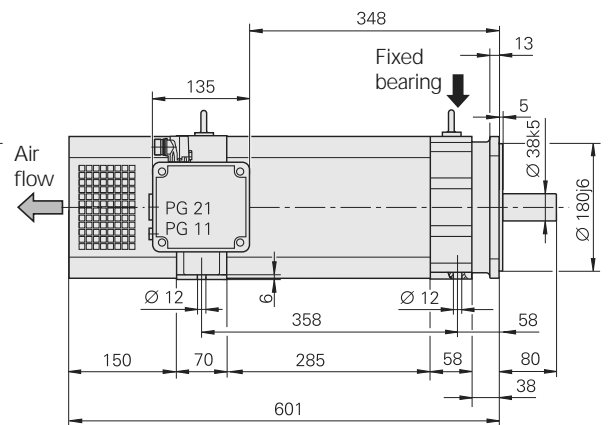
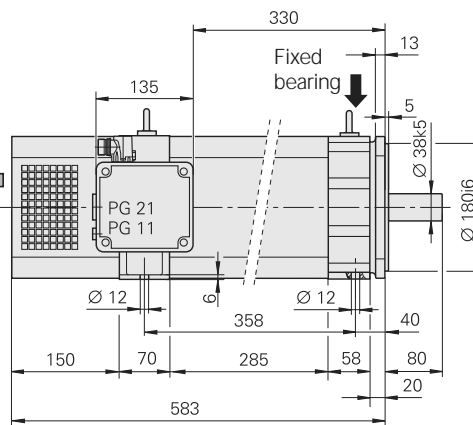
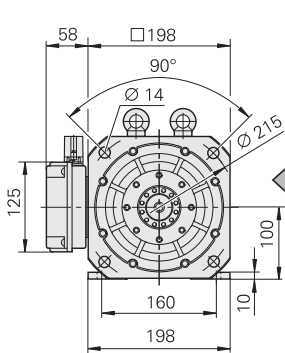

Asynchronous Motors with Solid Shaft

ASM 260 Series

Spindle motors with 2 pole pairs
 Rated power output 12 kW to 24 kW
 Choice of standard or high specification spindle bearing

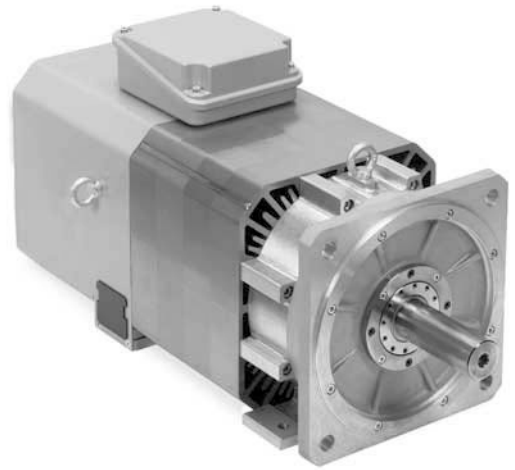

Motor	ASM 260M	ASM 260L	ASM 260U	ASM 260W
Rated voltage U_N	348 V	331 V	318 V	335 V
Rated power output P_N	15 kW	20 kW	24 kW	12 kW
Rated shaft speed n_N	1 500 min ⁻¹			750 min ⁻¹
Rated torque M_N (105 K)	96.0 Nm	128.0 Nm	153.0 Nm	153.0 Nm
Rated current I_N (105 K)	35.0 A	46.0 A	58.0 A	29.0 A
Efficiency	0,85			
Max. speed n_{max} ¹⁾ Standard bearing Spindle bearing*	8 000 min ⁻¹ 10 000 min ⁻¹ or 12 000 min ⁻¹		8 000 min ⁻¹ 10 000 min ⁻¹	
Max. current I_{max}	70 A	96 A	116 A	62 A
Weight m	112 kg	135 kg	158 kg	158 kg
Rotor inertia J	700 kgcm ²	920 kgcm ²	1 100 kgcm ²	1 100 kgcm ²
Protection	IP 54			
Fan Rated voltage U_L Rated current I_L Frequency f_L	3 × 400 V 0.35 A 50 Hz/60 Hz			
ID Motor with standard bearing Motor with spindle bearing 10 000 min ⁻¹ 12 000 min ⁻¹				

¹⁾The max. speed depends on the motor's application conditions, such as the shaft load
 (Contact SEM for further information).

* Please select when ordering

Rotatable connections

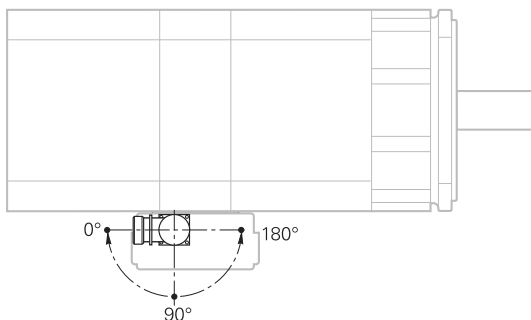

Dimensions in mm



Tolerancing ISO 8015
 ISO 2768 - m H
 < 6 mm: ±0.2 mm

ASM 260M

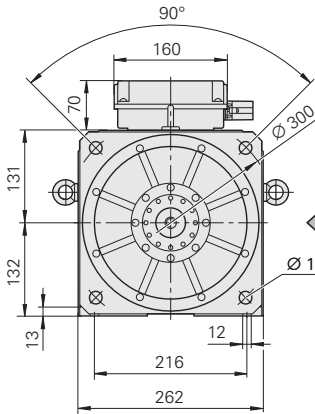

With standard bearing

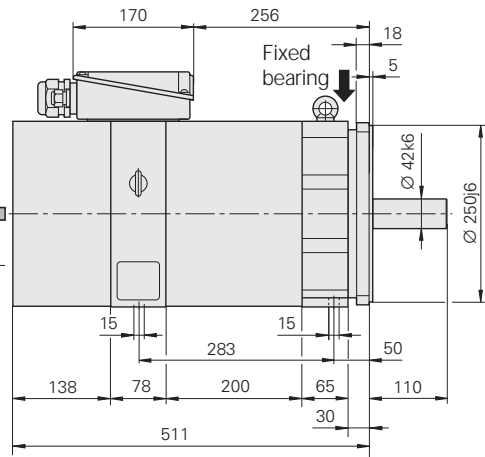

With high specification spindle bearing

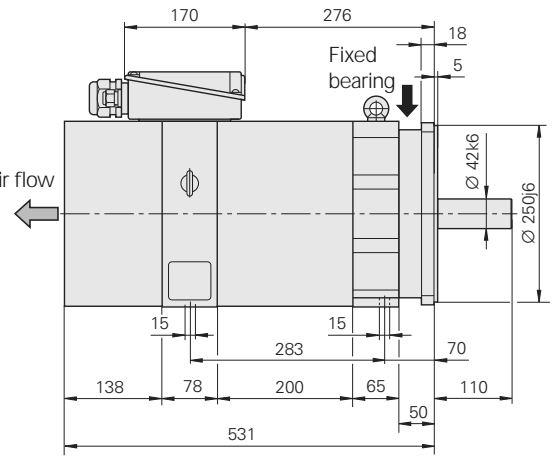

ASM 260L

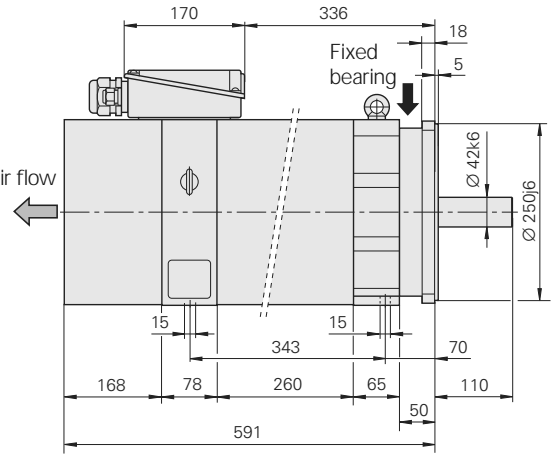
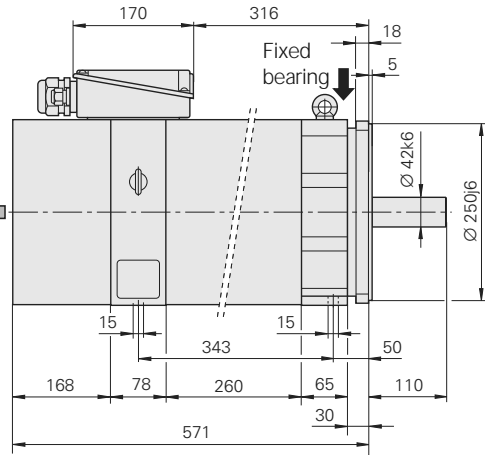
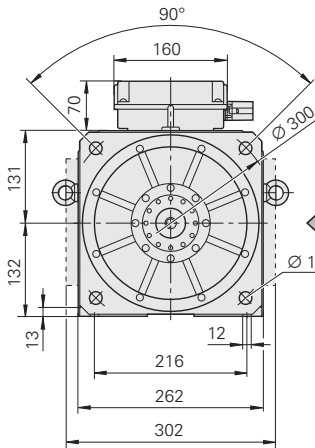

**ASM 260U
 ASM 260W**

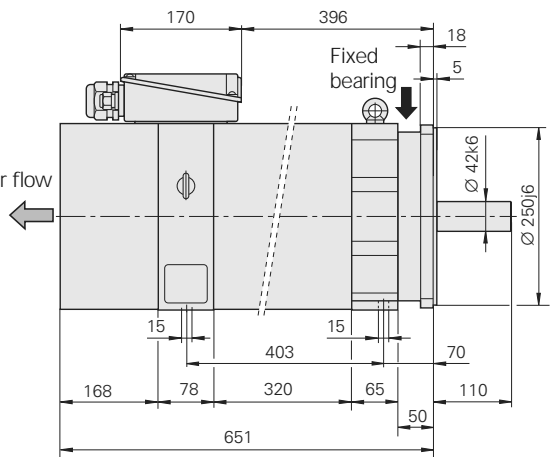
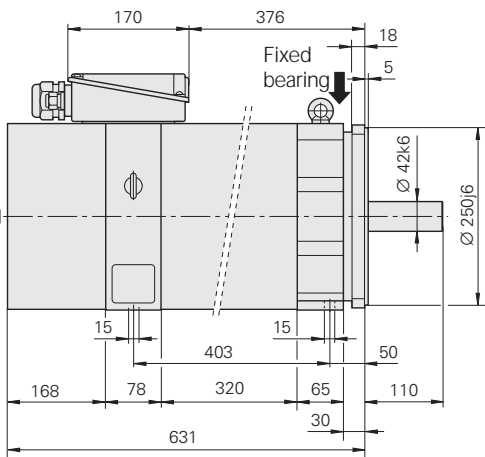
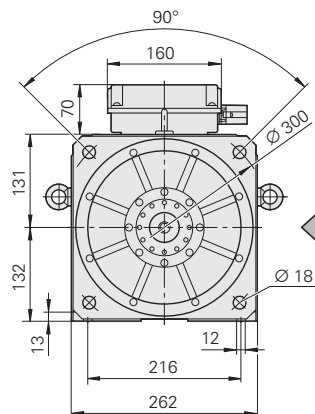

Asynchronous Motors with Solid Shaft

ASM 320 Series

Spindle motors with 2 pole pairs
 Rated power output 18 kW to 40 kW

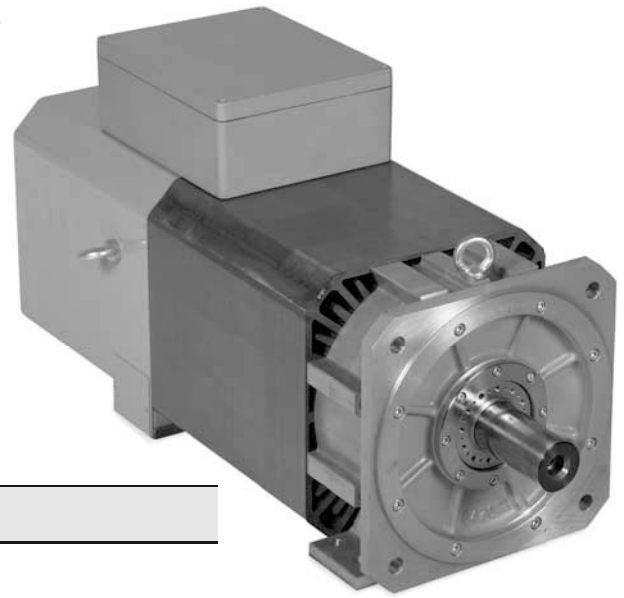

Motor	ASM 320M	ASM 320L	
Rated voltage U_N	317 V	315 V	
Rated power output P_N	32 kW	40 kW	
Rated shaft speed n_N	1500 min ⁻¹	1500 min ⁻¹	
Rated torque M_N (105 K)	203.7 Nm	254.6 Nm	
Rated current I_N (105 K)	77.5 A	99.0 A	
Efficiency	0.85	0.91	
Max. speed n_{max} ¹⁾ Standard bearing Spindle bearing	8000 min ⁻¹ 10000 min ⁻¹		
Max. current I_{max}	155 A	186 A	
Weight m	240 kg	280 kg	
Rotor inertia J	1870 kgcm ²	2300 kgcm ²	
Fan Rated voltage U_L Rated current I_L Frequency f_L	3 × 400 V 0.6 A 50 Hz/60 Hz		
ID Motor with standard bearing Motor with spindle bearing			

¹⁾The max. speed depends on the motor's application conditions, such as the shaft load (contact SEM for further information).

Rotatable connections

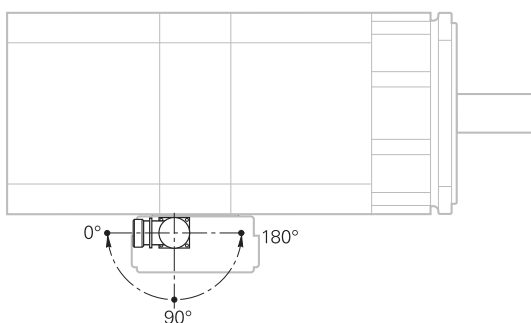

Dimensions in mm



Tolerancing ISO 8015
 ISO 2768 - m H
 < 6 mm: ±0.2 mm

ASM 320M

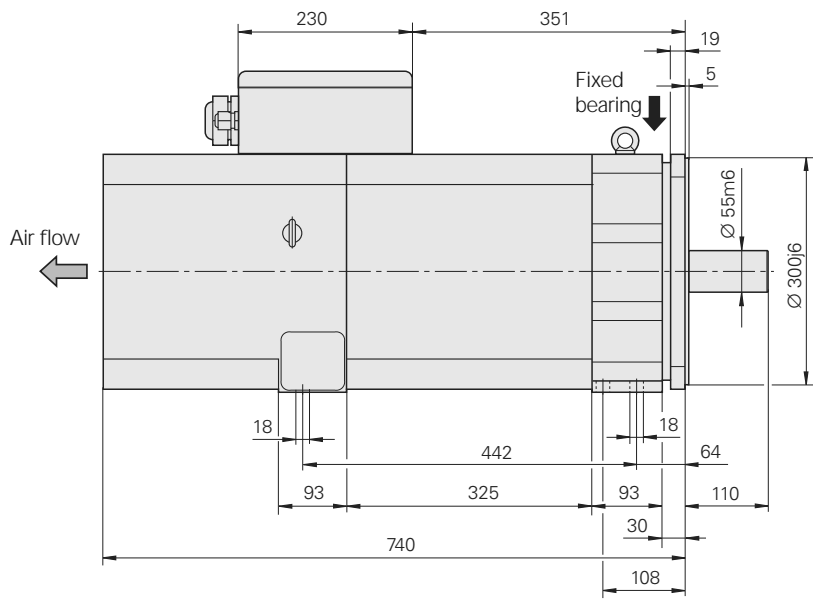
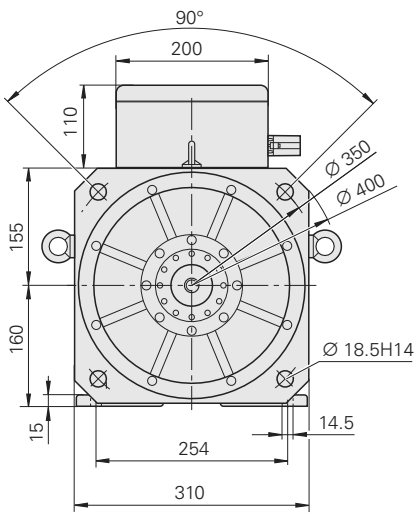

ASM 320L

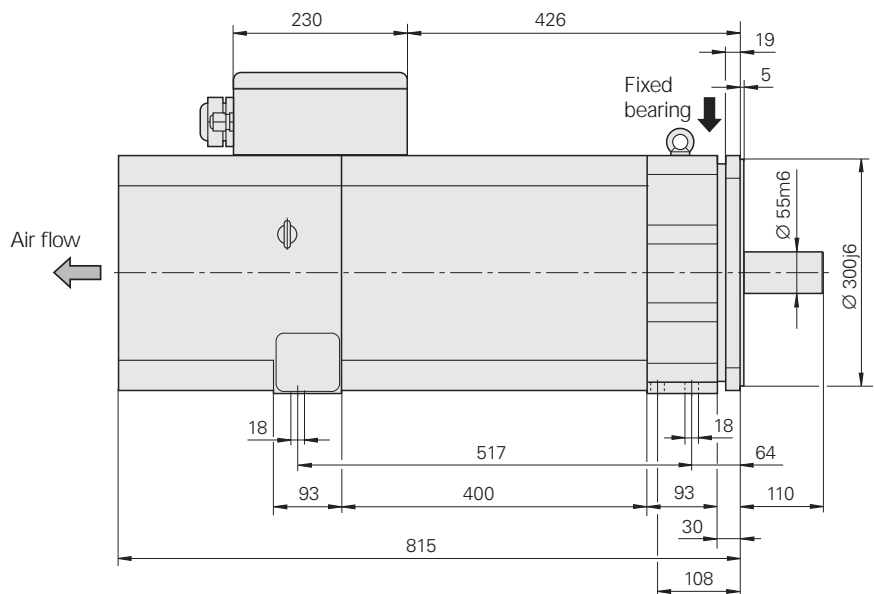
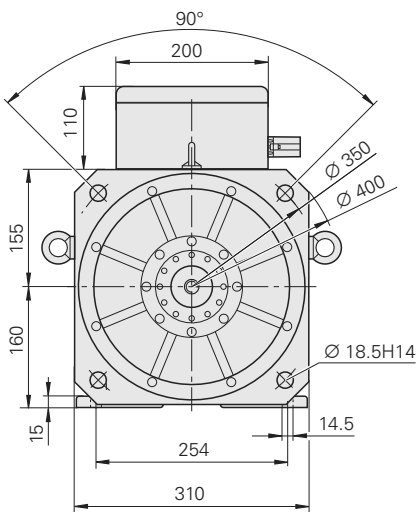

Asynchronous Motors with Hollow Shaft

ASM 200 UH

Hollow-shaft spindle motor with 2 pole pairs
 Rated power output to 10 kW
 With high specification spindle bearing



Motor	ASM 200 UH	
Rated voltage U_N	330 V	
Rated power output P_N	10.0 kW	
Rated shaft speed n_N	1 500 min ⁻¹	
Rated torque M_N (105 K)	63.7 Nm	
Rated current I_N (105 K)	25.0 A	
Efficiency	0.85	
Max. speed n_{max} ¹⁾ Spindle bearing	12 000 min ⁻¹	15 000 min ⁻¹
Max. current I_{max}	44 A	
Bore hole in shaft	Ø 9 mm	
Weight m	91 kg	
Rotor inertia J	405 kgcm ²	
Protection	IP 54	
Fan Rated voltage U_L Rated current I_L Frequency f_L	3 × 400 V 0.2 A 50 Hz/60 Hz	
ID Motor with spindle bearing		

¹⁾ The max. speed depends on the motor's application conditions, such as the shaft load (contact SEM for further information).

Rotatable connections

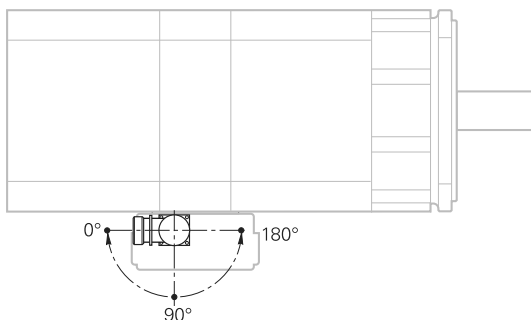

Asynchronous Motors with Hollow Shaft

ASM 260xH Series

Hollow-shaft spindle motor with 2 pole pairs
 Rated power output 15 kW to 22 kW
 With high specification spindle bearing

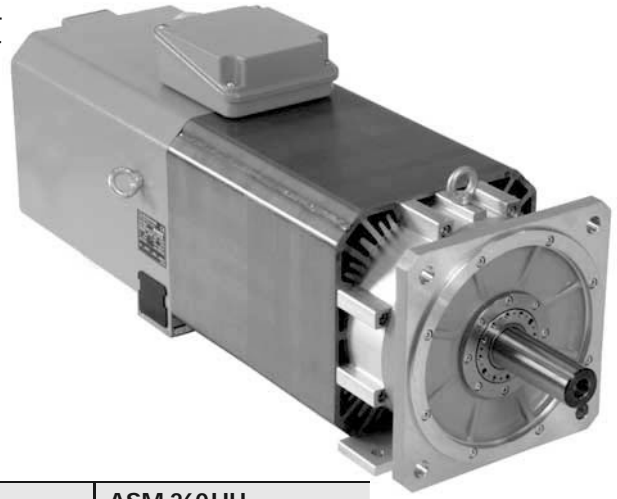

Motor	ASM 260MH	ASM 260LH	ASM 260UH
Rated voltage U_N	348 V	331 V	318 V
Rated power output P_N	15 kW	20 kW	22 kW
Rated shaft speed n_N	1 500 min ⁻¹		
Rated torque M_N (105 K)	96.0 Nm	128.0 Nm	140.0 Nm
Rated current I_N (105 K)	35.0 A	46.0 A	54.0 A
Efficiency	0.85		
Max. speed n_{max} ¹⁾ Spindle bearing*	12 000 min ⁻¹		10 000 min ⁻¹ or 12 000 min ⁻¹
Max. current I_{max}	70 A	96 A	116 A
Weight m	120 kg	143 kg	158 kg
Rotor inertia J	700 kgcm ²	920 kgcm ²	1 100 kgcm ²
Protection	IP 54		
Fan Rated voltage U_L Rated current I_L Frequency f_L	3 × 400 V 0.35 A 50 Hz/60 Hz		
ID Motor with spindle bearing 10 000 min ⁻¹ 12 000 min ⁻¹			

¹⁾ The max. speed depends on the motor's application conditions, such as the shaft load (contact SEM for further information).

* Please select when ordering

Rotatable connections

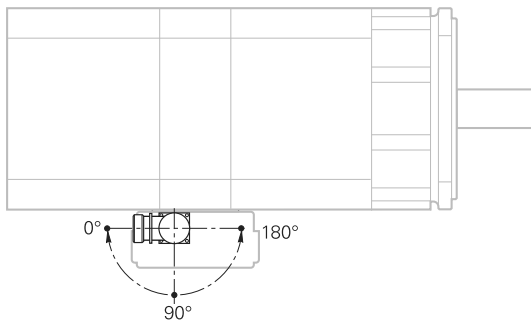

Asynchronous Motors

Characteristics of Power and Torque

ASM 200M

Duty cycle	Speed n	Power P	Torque M	Current I
S1	1500 min ⁻¹	5.5 kW	35.0 Nm	18.0 A
	6000 min ⁻¹	5.5 kW	8.8 Nm	–
	12000 min ⁻¹	5.5 kW	4.4 Nm	–
S6-60%	1500 min ⁻¹	7.0 kW	44.7 Nm	22.0 A
	6000 min ⁻¹	7.0 kW	11.2 Nm	–
	12000 min ⁻¹	7.0 kW	5.6 Nm	–
S6-40%	1500 min ⁻¹	7.9 kW	50.4 Nm	24.0 A
	6000 min ⁻¹	7.9 kW	12.6 Nm	–
	12000 min ⁻¹	7.9 kW	6.3 Nm	–
S6-25%	1500 min ⁻¹	9.5 kW	60.7 Nm	28.0 A
	6000 min ⁻¹	9.5 kW	15.2 Nm	–
	12000 min ⁻¹	9.5 kW	7.6 Nm	–

Power characteristic curve

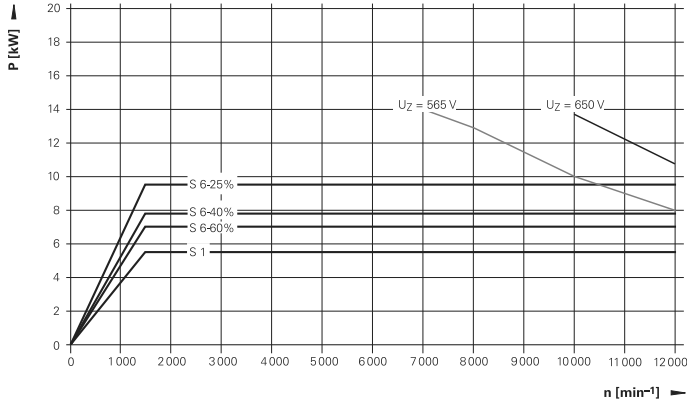

Torque characteristic curve

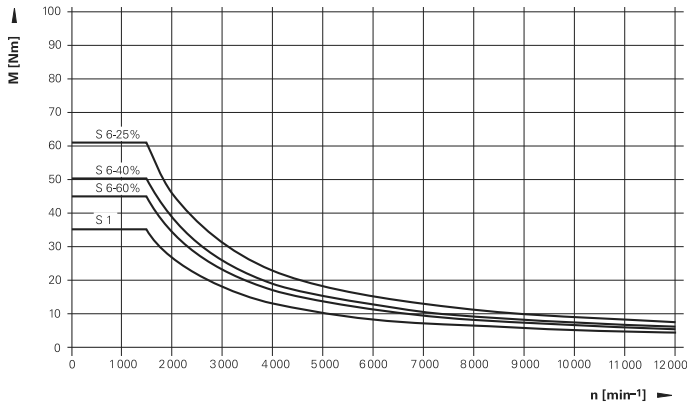

ASM 200L

Duty cycle	Speed n	Power P	Torque M	Current I
S1	1500 min ⁻¹	7.5 kW	47.8 Nm	20.1 A
	6000 min ⁻¹	7.5 kW	12.0 Nm	–
	12000 min ⁻¹	7.5 kW	6.0 Nm	–
S6-60%	1500 min ⁻¹	9.8 kW	62.6 Nm	24.0 A
	10700 min ⁻¹	9.8 kW	9.5 Nm	–
	12000 min ⁻¹	8.5 kW	6.8 Nm	–
S6-40%	1500 min ⁻¹	11.5 kW	73.4 Nm	27.0 A
	9000 min ⁻¹	11.5 kW	11.0 Nm	–
	12000 min ⁻¹	8.5 kW	6.8 Nm	–
S6-25%	1500 min ⁻¹	13.0 kW	83.0 Nm	31.0 A
	7500 min ⁻¹	13.0 kW	16.6 Nm	–
	12000 min ⁻¹	8.5 kW	6.8 Nm	–

Power characteristic curve

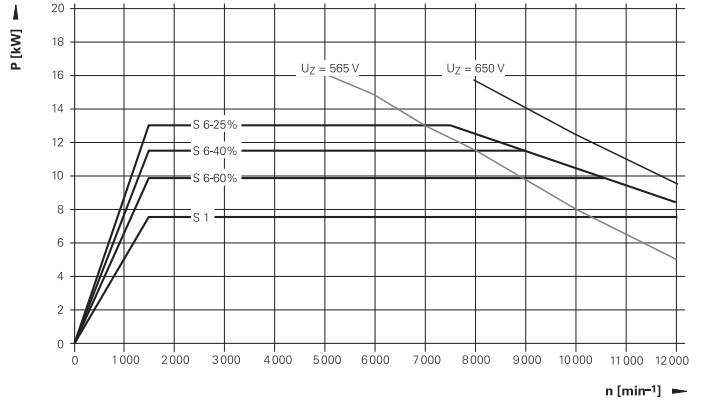

Torque characteristic curve

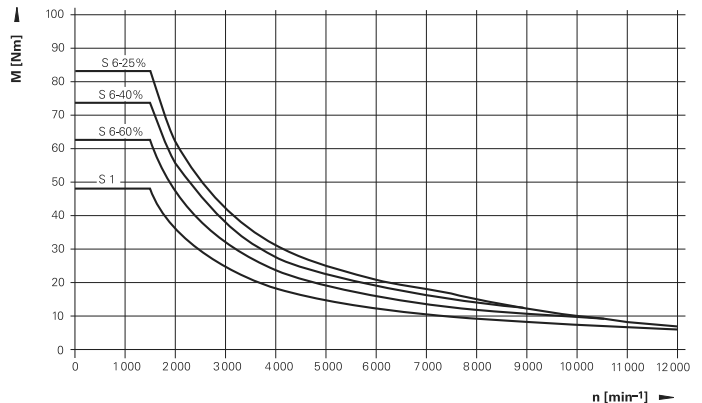

ASM 200 U

Duty cycle	Speed n	Power P	Torque M	Current I
S1	1 500 min ⁻¹	10.0 kW	63.7 Nm	25.0 A
	11 000 min ⁻¹	10.0 kW	8.7 Nm	–
	12 000 min ⁻¹	8.0 kW	6.4 Nm	–
S6-60%	1 500 min ⁻¹	12.5 kW	79.8 Nm	29.0 A
	10 000 min ⁻¹	12.5 kW	11.9 Nm	–
	12 000 min ⁻¹	10.0 kW	8.0 Nm	–
S6-40%	1 500 min ⁻¹	14.0 kW	89.4 Nm	32.0 A
	9 000 min ⁻¹	14.0 kW	19.1 Nm	–
	12 000 min ⁻¹	11.0 kW	8.8 Nm	–
S6-25%	1 500 min ⁻¹	17.0 kW	108.6 Nm	37.0 A
	7 500 min ⁻¹	17.0 kW	21.7 Nm	–
	12 000 min ⁻¹	12.0 kW	9.5 Nm	–

Power performance curve

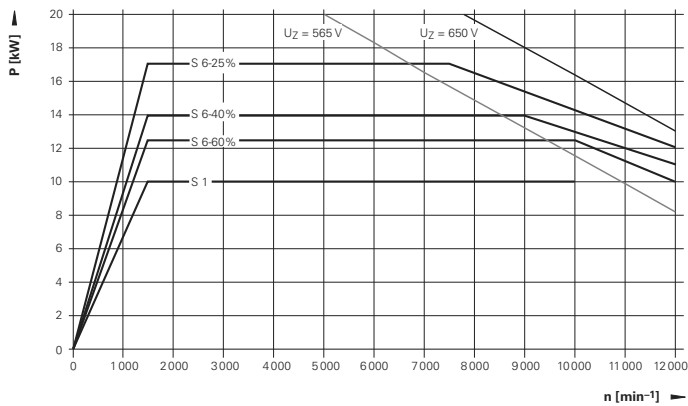

Torque performance curve

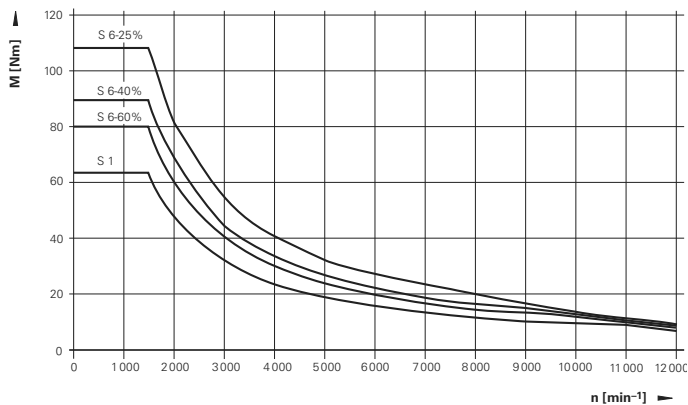

ASM 200 UH

Duty cycle	Speed n	Power P	Torque M	Current I
S1	1 500 min ⁻¹	10.0 kW	63.7 Nm	25.0 A
	11 000 min ⁻¹	10.0 kW	8.7 Nm	–
	12 000 min ⁻¹	8.0 kW	6.4 Nm	–
	15 000 min ⁻¹	4.0 kW	2.5 Nm	–
S6-60%	1 500 min ⁻¹	12.5 kW	79.8 Nm	29.0 A
	10 000 min ⁻¹	12.5 kW	11.9 Nm	–
	12 000 min ⁻¹	10.0 kW	8.0 Nm	–
	15 000 min ⁻¹	5.0 kW	3.2 Nm	–
S6-40%	1 500 min ⁻¹	14.0 kW	89.4 Nm	32.0 A
	9 000 min ⁻¹	14.0 kW	19.1 Nm	–
	12 000 min ⁻¹	11.0 kW	8.8 Nm	–
	15 000 min ⁻¹	6.0 kW	3.8 Nm	–
S6-25%	1 500 min ⁻¹	17.0 kW	108.6 Nm	37.0 A
	7 500 min ⁻¹	17.0 kW	21.7 Nm	–
	12 000 min ⁻¹	12.0 kW	9.5 Nm	–
	15 000 min ⁻¹	7.0 kW	4.5 Nm	–

Power performance curve

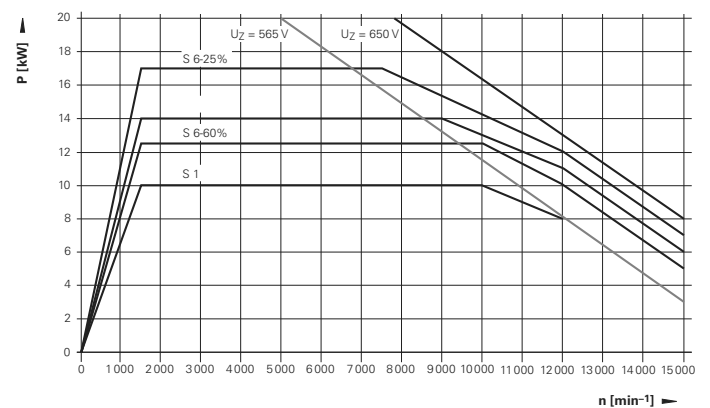

Torque performance curve

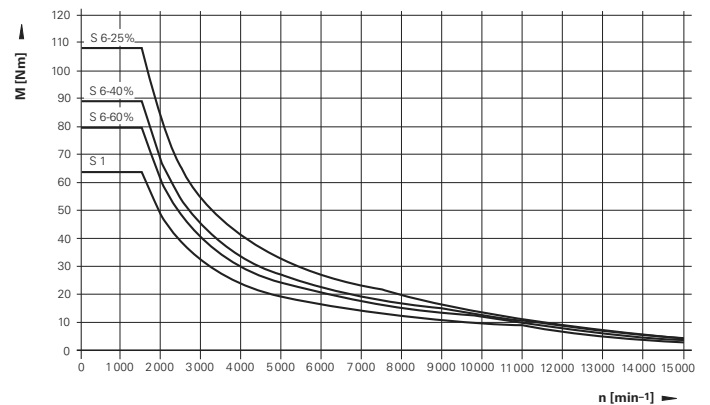

ASM 260M, ASM 260MH

Duty cycle	Speed n	Power P	Torque M	Current I
S1	1 500 min ⁻¹	15.0 kW	95.5 Nm	35.0 A
	6 500 min ⁻¹	15.0 kW	22.0 Nm	–
	10 000 min ⁻¹	10.0 kW	9.5 Nm	–
	12 000 min ⁻¹	4.0 kW	3.2 Nm	–
S6-60%	1 500 min ⁻¹	20.0 kW	127.3 Nm	43.3 A
	5 000 min ⁻¹	20.0 kW	38.2 Nm	–
	9 000 min ⁻¹	13.5 kW	14.3 Nm	–
S6-40%	1 500 min ⁻¹	25.0 kW	159.2 Nm	52.3 A
	4 500 min ⁻¹	25.0 kW	53.1 Nm	–
	8 000 min ⁻¹	16.8 kW	20.1 Nm	–
S6-25%	1 500 min ⁻¹	32.0 kW	203.7 Nm	65.0 A
	4 000 min ⁻¹	32.0 kW	76.4 Nm	–
	6 000 min ⁻¹	23.7 kW	37.7 Nm	–

Power performance curve

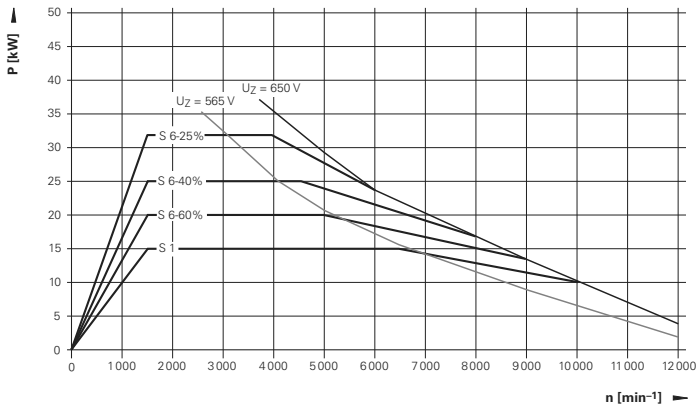

Torque performance curve

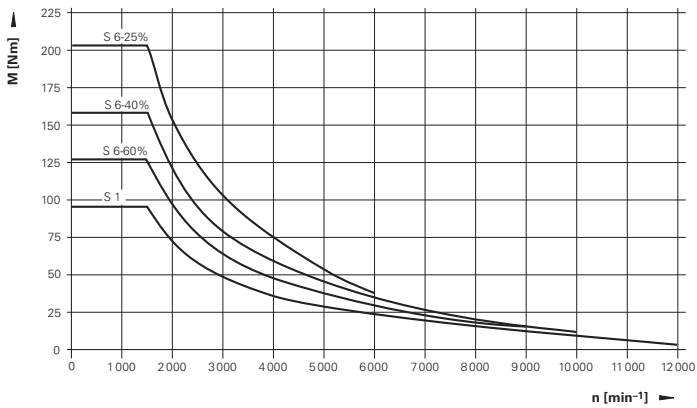

ASM 260L, ASM 260LH

Duty cycle	Speed n	Power P	Torque M	Current I
S1	1 500 min ⁻¹	20.0 kW	127.3 Nm	46.0 A
	6 500 min ⁻¹	20.0 kW	29.4 Nm	–
	10 000 min ⁻¹	13.0 kW	12.4 Nm	–
	12 000 min ⁻¹	8.0 kW	6.4 Nm	–
S6-60%	1 500 min ⁻¹	25.0 kW	159.2 Nm	56.0 A
	6 000 min ⁻¹	25.0 kW	39.4 Nm	–
	10 000 min ⁻¹	16.0 kW	15.3 Nm	–
	12 000 min ⁻¹	8.0 kW	6.4 Nm	–
S6-40%	1 500 min ⁻¹	30.0 kW	191.0 Nm	65.0 A
	5 500 min ⁻¹	30.0 kW	52.1 Nm	–
	10 000 min ⁻¹	17.5 kW	16.7 Nm	–
S6-25%	1 500 min ⁻¹	37.0 kW	235.5 Nm	79.0 A
	5 000 min ⁻¹	37.0 kW	70.7 Nm	–
	8 000 min ⁻¹	24.0 kW	28.6 Nm	–

Power performance curve

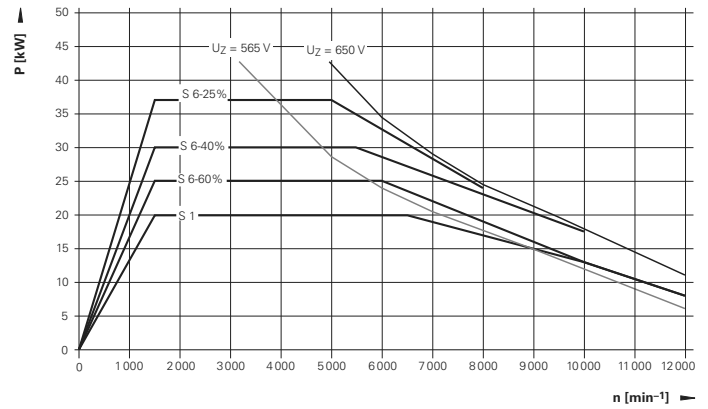

Torque performance curve

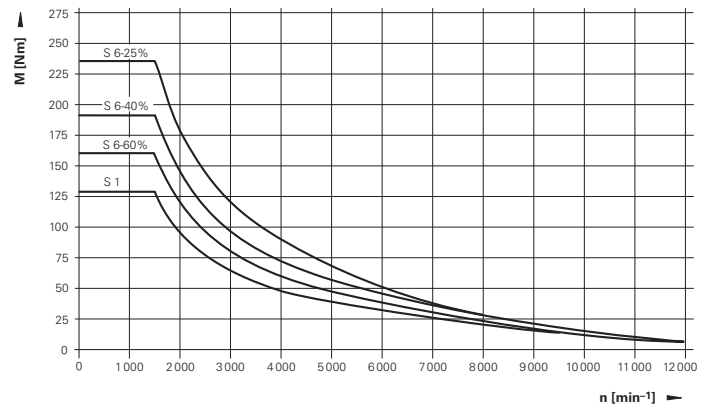

ASM 260U

Duty cycle	Speed n	Power P	Torque M	Current I
S1	1 500 min ⁻¹	24.0 kW	152.8 Nm	58.0 A
	7 400 min ⁻¹	24.0 kW	31.0 Nm	–
	10 000 min ⁻¹	18.0 kW	17.2 Nm	–
S6-60%	1 500 min ⁻¹	30.0 kW	191.0 Nm	67.2 A
	7 000 min ⁻¹	30.0 kW	40.9 Nm	–
	10 000 min ⁻¹	22.5 kW	21.5 Nm	–
S6-40%	1 500 min ⁻¹	38.0 kW	241.9 Nm	81.8 A
	5 500 min ⁻¹	38.0 kW	66.0 Nm	–
	10 000 min ⁻¹	26.0 kW	24.8 Nm	–
S6-25%	1 500 min ⁻¹	48.0 kW	305.6 Nm	100.6 A
	4 500 min ⁻¹	48.0 kW	101.9 Nm	–
	7 000 min ⁻¹	41.0 kW	55.9 Nm	–

Power performance curve

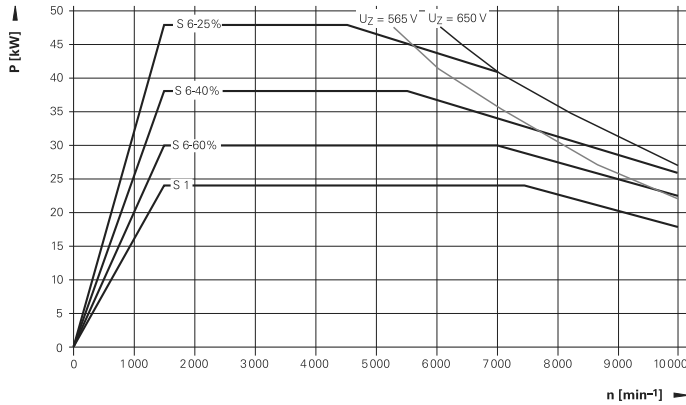

Torque performance curve

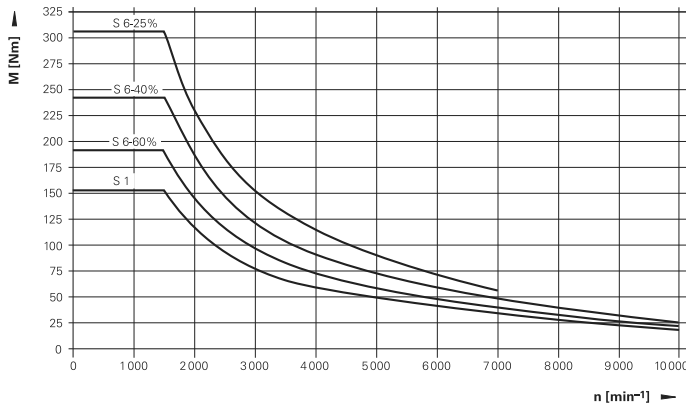

ASM 260UH

Duty cycle	Speed n	Power P	Torque M	Current I
S1	1 500 min ⁻¹	22.0 kW	140.1 Nm	54.0 A
	7 400 min ⁻¹	22.0 kW	28.4 Nm	–
	10 000 min ⁻¹	16.0 kW	15.3 Nm	–
S6-60%	1 500 min ⁻¹	30.0 kW	191.0 Nm	67.0 A
	6 500 min ⁻¹	30.0 kW	44.1 Nm	–
	10 000 min ⁻¹	20.0 kW	19.5 Nm	–
S6-40%	1 500 min ⁻¹	35.0 kW	222.8 Nm	77.0 A
	6 500 min ⁻¹	35.0 kW	66.8 Nm	–
	10 000 min ⁻¹	24.0 kW	22.9 Nm	–
S6-25%	1 500 min ⁻¹	46.0 kW	286.5 Nm	97.0 A
	5 000 min ⁻¹	46.0 kW	85.9 Nm	–
	10 000 min ⁻¹	27.0 kW	25.8 Nm	–

Power performance curve

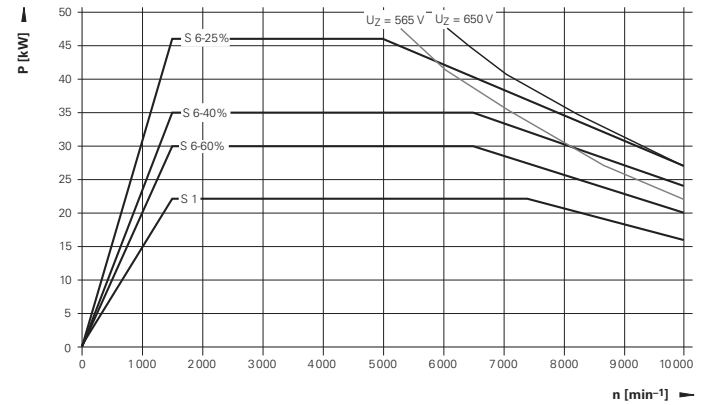

Torque performance curve

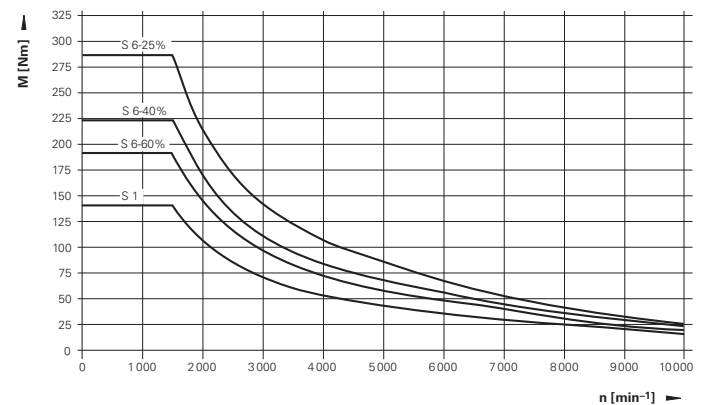

ASM 260W

Duty cycle	Speed n	Power P	Torque M	Current I
S1	750 min ⁻¹	12.0 kW	152.8 Nm	29.0 A
	5000 min ⁻¹	12.0 kW	22.9 Nm	–
	10000 min ⁻¹	4.0 kW	3.8 Nm	–
S6-60%	750 min ⁻¹	17.5 kW	222.8 Nm	38.1 A
	3000 min ⁻¹	17.5 kW	55.7 Nm	–
	6000 min ⁻¹	11.3 kW	18.0 Nm	–
S6-40%	750 min ⁻¹	22.0 kW	280.1 Nm	46.4 A
	2500 min ⁻¹	22.0 kW	84.0 Nm	–
	3500 min ⁻¹	19.0 kW	51.8 Nm	–

Power performance curve

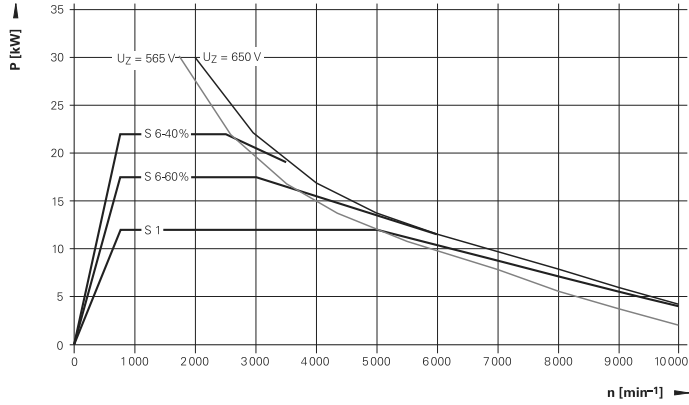

Torque performance curve

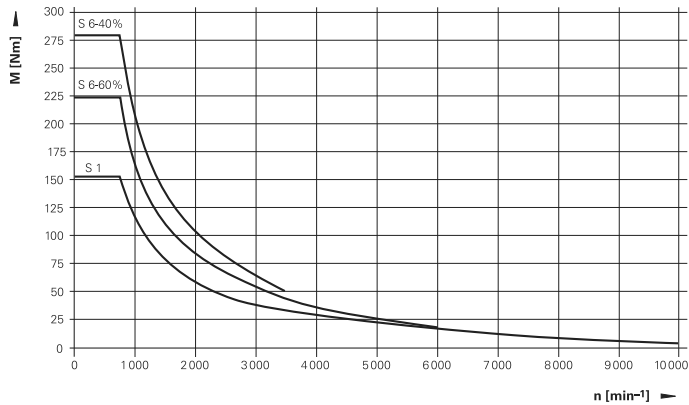

ASM 320M

Duty cycle	Speed n	Power P	Torque M	Current I
S1	1 500 min ⁻¹	32.0 kW	203.7 Nm	77.5 A
	5 500 min ⁻¹	32.0 kW	55.0 Nm	–
	10 000 min ⁻¹	19.5 kW	18.6 Nm	–
S6-60%	1 500 min ⁻¹	43.0 kW	273.7 Nm	98.0 A
	5 500 min ⁻¹	43.0 kW	71.5 Nm	–
	10 000 min ⁻¹	25.0 kW	23.9 Nm	–
S6-40%	1 500 min ⁻¹	53.0 kW	337.4 Nm	118.0 A
	5 500 min ⁻¹	53.0 kW	86.2 Nm	–
	6 000 min ⁻¹	48.0 kW	76.4 Nm	–

Power performance curve

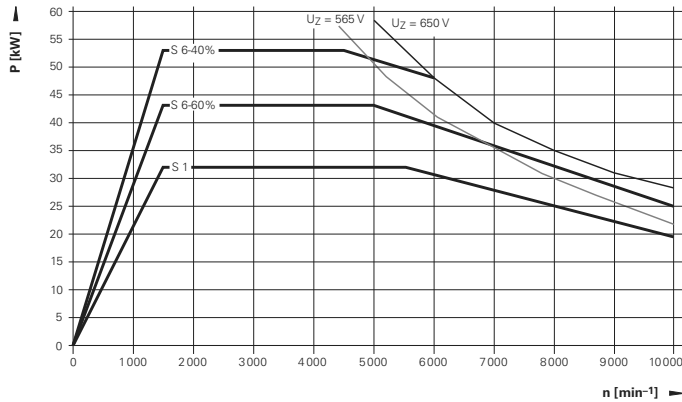

Torque performance curve

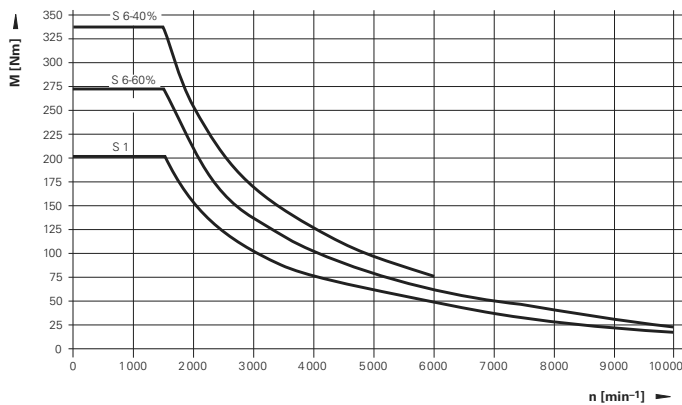

ASM 320L

Duty cycle	Speed n	Power P	Torque M	Current I
S1	1 500 min ⁻¹	40.0 kW	254.6 Nm	99.0 A
	5 000 min ⁻¹	40.0 kW	77.9 Nm	–
	10 000 min ⁻¹	21.0 kW	21.0 Nm	–
S6-60%	1 500 min ⁻¹	53.0 kW	337.4 Nm	123.0 A
	4 500 min ⁻¹	53.0 kW	112.5 Nm	–
	10 000 min ⁻¹	24.0 kW	22.9 Nm	–
S6-40%	1 500 min ⁻¹	66.0 kW	420.2 Nm	148.0 A
	4 500 min ⁻¹	66.0 kW	140.1 Nm	–
	10 000 min ⁻¹	28.0 kW	26.7 Nm	–

Power performance curve

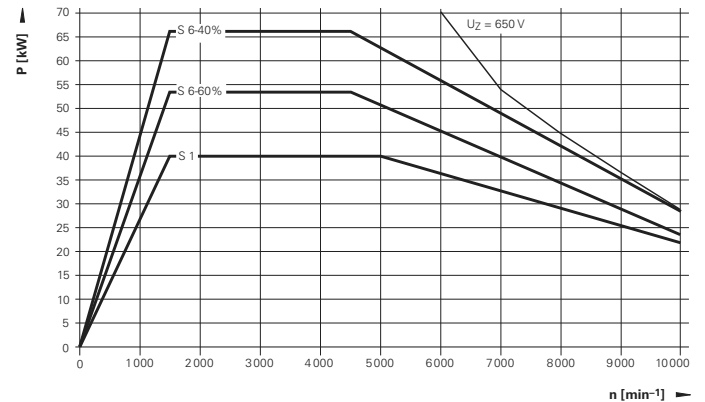

Torque performance curve

