

SPINDLE PROGRAMME  
MILLING



MILLING SPINDLES | BEST SELECTION

**WEISS**

G M B H

WEISS Spindeltechnologie GmbH  
A Siemens Company

GSS | GLOBAL SPINDLE SOLUTIONS



## MILLING SPINDLES

MILLING  
FOR EVERY APPLICATION  
- MORE THAN 1,000  
DRIVE SOLUTIONS -  
FROM ECONOMICAL  
TO HIGH PERFORMANCE

## WEISS - MILLING SPINDLES BEST SELECTION

<b>Catalogue spindles</b>	Overview	4
	Performance characteristics	5
<b>Standard series</b>	Overview	6
	Performance characteristics	7
	Spindles with asynchronous technology	8
	Spindles with synchronous technology	9
<b>Individual designs</b>	Performance characteristics	10
	Reference spindles	11
	Spindle data	12
<b>Contact   Enquiries</b>	Your contact	18
	Fax enquiry form	19



WEISS Spindeltechnologie GmbH  
A Siemens Company

# CATALOGUE SPINDLES

# GSS

## MILLING

### CATALOGUE SPINDLES ON A HIGH LEVEL – ECS - MOTOR SPINDLE 2SP1

The ECS motor spindle 2SP1 is the ideal drive solution for main spindles in standard milling machines and machining centres. 2SP1 motor spindles have many strong arguments, particularly in comparison with belt-driven solutions:

#### Advantages of the 2SP1 motor spindles:

- ⊕ cost-efficient solutions compared to current belt-driven solutions, and less expensive than customer-specific motor spindle designs
- ⊕ as desired by customer, hydraulic or pneumatic tool unclamp unit
- ⊕ when having pneumatic tool release a hydraulic unit is not required
- ⊕ integrated sensor system (for indexing and monitoring of tool changes)
- ⊕ worldwide system solution provider including spindles from one source at Siemens
- ⊕ higher speeds and shorter acceleration time than conventional solutions
- ⊕ Design with high rigidity
- ⊕ compact solution
- ⊕ fewer parts and less installation efforts compared to belt – driven solution



**ECS motor spindle 2SP1 spectrum**

Order No.	Rated Power	Rated Torque	Rated speed	Rated Current	Rated Power	Rated Torque	Rated Power	Rated Torque	Rated speed	Rated Current	Max. speed
	S1-100% (kW)	S1-100% (Nm)		S1-100% (A)	S6-40% (kW)	S6-40% (Nm)	S1-100% (kW)	S1-100% (Nm)		S1-100% (A)	
<b>Synchronous</b>	star operation						delta operation				
2SP1202-1HA -1 D F2	12.0	42	2,700	30	12.0	55					15,000
2SP1202-1HB -2 D F2	15.5	42	3,500	42	15.5	55					18,000
2SP1204-1HA -1 D F2	26.4	84	3,000	60	26.4	110					15,000
2SP1204-1HB -2 D F2	35.0	78	4,300	79	35.0	110					18,000
<b>Asynchronous</b>											
2SP1253-8HA0 -0-2	13.2	70	1,800	28	18.9	100	13.2	32	4,000	29	10,000
2SP1253-8HA0 -1D-2	13.2	70	1,800	28	18.9	100	13.2	32	4,000	29	15,000
2SP1255-8HA0 -0-2	11.7	140	800	30	16.7	200	11.7	62	1,800	29	10,000
2SP1255-8HA0 -1D-2	11.7	140	800	30	16.7	200	11.7	62	1,800	29	15,000
<b>Synchronous</b>											
2SP1253-1HA0 -0-2	26.0	100	2,500	53	29.0	130					10,000
2SP1253-1HB0 -1D-2	35.0	100	3,300	68	38.0	130					15,000
2SP1255-1HA0 -0-2	46.3	170	2,600	95	55.0	236					10,000
2SP1255-1HB0 -1D-2	53.4	170	3,000	120	64.0	236					15,000

**Options for ECS motor spindle 2SP1**

**Sensor system**

- B: Sensor "Tool clamped"
- C: B + Sensor "draw bar in release position"
- D: C + sensor "clamped without tool"
- F: D + Sensor "position release piston"

**Tool mounts**

- A: Tool mount SK 40
- B: Tool mount BT40 45
- C: Tool mount CAT 40
- D: Tool mount HSK A 63
- E: Tool mount BT 40 30

**Coolant**

- 1: closed cooling jacket
- 2: closed cooling jacket and tool interior coolant
- 3: closed cooling jacket, tool interior coolant and ring for external WZG cooling (only for 2SP120..)

**Tool clamping and release device**

- 0: pneumatic
- 1: hydraulic



The extensive program of dimensions, outputs, and descriptions of 2SP1 motor spindles can be found in our catalogue or on our homepage at: [www.weissgmbh.de](http://www.weissgmbh.de)



WEISS Spindeltechnologie GmbH  
A Siemens Company

# STANDARD SERIES

# GSS

## MILLING

### Standard series set the standard!

Milling spindles from the standard series offer top performance at affordable prices: At maximum speeds of up to 40,000 rpm and rated outputs (S1–100%) of up to 80 kW, you'll find a broad selection of high-class and field tested motor spindle units.

Spindle units from the standard series prove that good quality, leading technology, and high performance need not necessarily be expensive. Batch production with a high degree of non-variable parts allows consistent exploitation of synergies and the economy of scale in material procurement and production. These savings are passed on to our customers.



With about 20 spindle models from which to select, the standard series offers a suitable solution for almost every application. Take advantage of the economic benefits that Siemens has to offer!

#### Advantages of standard series:

- ⊕ affordable to procure
- ⊕ short delivery
- ⊕ field tested and proven
- ⊕ latest state-of-the-art design
- ⊕ affordable spindle service through optional stocking of replacement spindles and parts

Standard series MILLING

ASYNCHRONOUS TECHNOLOGY				SPINDLE NOSE DIN 55026-	SYNCHRONOUS TECHNOLOGY				
SPINDLE NO:	DIAMETER	MAX speed	RATED OUTPUT S1-100%		RATED OUTPUT S1-100%	MAX speed	DIAMETER	SPINDLE NO:	
F150A.30.18	150 mm	30,000 rpm	18 kW	E40	11 kW	30,000 rpm	150 mm	F150S.30.11	
F150A.40.18	150 mm	40,000 rpm	18 kW		A63	29 kW	18,000 rpm	150 mm	F150S.18.29
F170A.18.46	170 mm	18,000 rpm	46 kW			41 kW	18,000 rpm	170 mm	F170S.18.41
F170A.24.46	170 mm	24,000 rpm	46 kW	28 kW		18,000 rpm	210 mm	F210S.18.28	
F210A.18.18	210 mm	18,000 rpm	18 kW	28 kW		20,000 rpm	210 mm	F210S.20.28	
F210A.24.18	210 mm	24,000 rpm	18 kW	35 kW		18,000 rpm	230 mm	F230S.18.35	
F230A.18.40	230 mm	18,000 rpm	40 kW	A100		78 kW	10,000 rpm	285 mm	F285S.10.78
F230A.24.40	230 mm	24,000 rpm	40 kW			78 kW	14,000 rpm	285 mm	F285S.14.78
F230A.30.80	230 mm	30,000 rpm	80 kW						
F285A.10.32	285 mm	10,000 rpm	32 kW						
F285A.15.32	285 mm	15,000 rpm	32 kW						

PERFORMANCE CHARACTERISTICS

**Tool interface:**

HSK in all standard sizes, optional ISO for low speed

**Taper and planar surface:**

Filtered compressed air in the taper and on the planar surface for cleaning and for lasting precision from of the tool interface

**Precision spindle bearings:**

Steel or hybrid bearings for maximum precision

**Bearing lubrication:**

Grease for life Oil-air lubrication

**Bearing temperature monitoring:**

PT100 or PT1000

**Sealing on working end:**

Labyrinth with air purge

**Motor temperature monitoring:**

Compatible with all frequency converter types

**Encoder:**

Vector controlled operation compatible with all frequency converter types

**Tool clamp:**

Tool clamping with power drawbar system

**Tool release unit:**

Hydraulic for minimised tool changeover times, optional available with pneumatic cylinder

**Drawbar position monitoring:**

Analogue or digital

**Rotary joints:**

Cutting coolant liquid up to 80 bar, minimal quantity lubrication and dry machining possible without modification

**Options:**

- Sensor, axial spindle growth: Direct interaction to length compensation in the machine
- Acceleration sensor: Determination and monitoring of occurring acceleration to protect the spindle and for trend analysis
- external cutting coolant (nozzles)



WEISS Spindeltechnologie GmbH  
A Siemens Company

DIMENSIONS

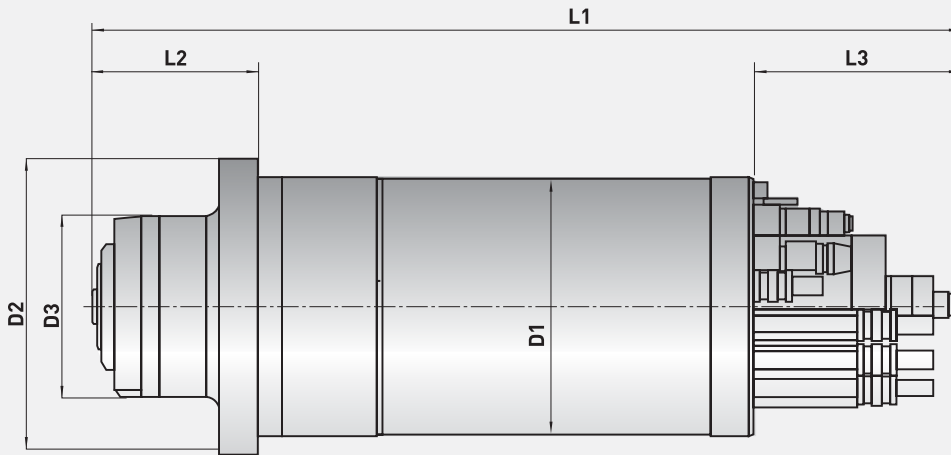

MILLING | STANDARD SPINDLES

**ASYNCHRONOUS TECHNOLOGY**

Model no.	Tool Interface [HSK-]	Lubrication	Max. speed	Rated Power S1-100 %	Rated Torque S1-100 %	Rated speed	Rated Current	D1 [mm]	D2 [mm]	D3 [mm]	L1 [mm]	L2 [mm]	L3 [mm]	Weight [kg]
F150A.30.18	E40	Grease	30,000 rpm	18 kW	12 Nm	14,800 rpm	38 A	150	190	150	571	170	90	92
F150A.40.18	E40	Oil-air	40,000 rpm	18 kW	12 Nm	14,800 rpm	38 A	150	190	150	571	170	90	92
F170A.18.46	A63	Grease	18,000 rpm	46 kW	45 Nm	9,880 rpm	98 A	170	200	150	787	122	111	100
F170A.24.46	A63	Oil-air	24,000 rpm	46 kW	45 Nm	9,880 rpm	98 A	170	200	150	787	122	111	100
F210A.18.18	A63	Grease	18,000 rpm	18 kW	60 Nm	2,860 rpm	49 A	210	250	152	748	152	211	125
F210A.24.18	A63	Oil-air	24,000 rpm	18 kW	60 Nm	2,860 rpm	49 A	210	250	152	748	152	211	125
F230A.18.40	A63	Grease	18,000 rpm	40 kW	46 Nm	8,400 rpm	81 A	230	280	152	768	152	211	140
F230A.24.40	A63	Oil-air	24,000 rpm	40 kW	46 Nm	8,400 rpm	81 A	230	280	152	768	152	211	140
F230A.30.80	A100	Grease	30,000 rpm	80 kW	46 Nm	16,500 rpm	160 A	230	280	154	676	115	141	140
F285A.10.32	A100	Grease	10,000 rpm	32 kW	300 Nm	1,020 rpm	125 A	285	340	208	965	200	229	310
F285A.15.32	A100	Oil-air	15,000 rpm	32 kW	300 Nm	1,020 rpm	125 A	285	340	2508	965	200	229	310



**A detailed data sheet for all spindle numbers can be downloaded from our homepage at: [www.weissgmbh.de](http://www.weissgmbh.de)**

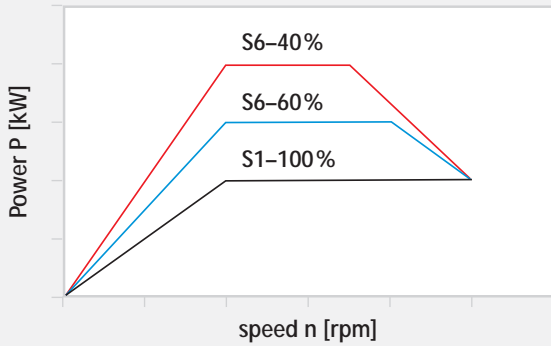

**POWER CHARACTERISTICS**

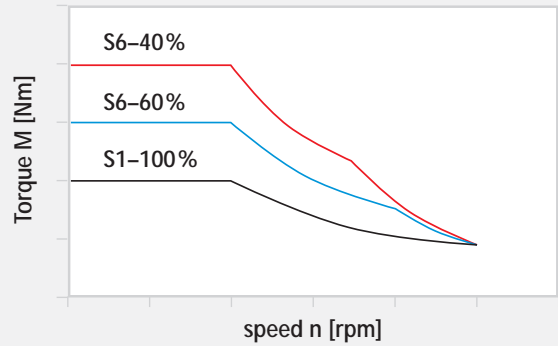

**TORQUE CHARACTERISTICS**



MILLING | STANDARD SPINDLES  
**SYNCHRONOUS TECHNOLOGY**

Model no.	Tool Interface [HSK-]	Lubrication	Max speed	Rated Power S1-100 %	Rated Torque S1-100 %	Rated speed	Rated Current	D1 [mm]	D2 [mm]	D3 [mm]	L1 [mm]	L2 [mm]	L3 [mm]	Weight [kg]
F150S.30.11	E40	Grease	30,000 rpm	11 kW	13 Nm	8,000 rpm	20 A	150	190	150	571	170	90	92
F150S.18.29	A63	Grease	18,000 rpm	18 kW	35 Nm	8,000 rpm	76 A	150	150	126	695	70	115	65
F170S.18.41	A63	Grease	18,000 rpm	41 kW	56 Nm	7,000 rpm	91 A	170	170	150	787	122	111	100
F210S.18.28	A63	Grease	18,000 rpm	28 kW	63 Nm	4,200 rpm	77 A	210	210	152	748	152	211	125
F210S.20.28	A63	Oil-air	20,000 rpm	28 kW	63 Nm	4,200 rpm	77 A	210	210	152	748	152	211	125
F230S.18.35	A63	Grease	18,000 rpm	35 kW	75 Nm	4,500 rpm	83 A	230	230	152	768	152	211	150
F285S.10.78	A100	Grease	10,000 rpm	78 kW	250 Nm	3,000 rpm	162 A	285	285	208	965	200	229	310
F285S.14.78	A100	Oil-air	14,000 rpm	78 kW	250 Nm	3,000 rpm	162 A	285	285	208	965	200	229	310

→ A detailed data sheet for all spindle numbers can be downloaded from our homepage at: [www.weissgmbh.de](http://www.weissgmbh.de)



WEISS Spindeltechnologie GmbH  
A Siemens Company

# GSS

# INDIVIDUAL - DESIGNS MILLING

## INDIVIDUALITY and FLEXIBILITY

Its more than one thousand individual designs underscoring WEISS GmbH's to claim as the number one spot globally in the area of milling.

WEISS offers solutions for nearly all machines: from small milling machines to machining centres up to large portal milling machines. WEISS know-how is in constant demand when it comes to milling spindles, from manufacturer and users from around the world looking to keep their drive solutions on the cutting edge of technology and affordability.

Flexibility is the key word when it comes to the development of customer-tailored milling spindles. The developers and engineers at WEISS oriented themselves completely to the requirements of your machine concept. – **Test the strength of WEISS by requesting your own personal spindle bid.**

## PREVIOUSLY REALISED PERFORMANCE PARAMETERS :

■ Output (S1–100%):	up to <b>130 kW</b>
■ Torque:	up to <b>3,280 Nm</b>
■ Max speed:	up to <b>40,000 rpm (4 pole)</b> up to <b>80,000 rpm (2 pole)</b>
■ Spindle weight:	between <b>10 kg</b> up to <b>1,500 kg</b>
■ Run-out:	from <b>1 µm</b>

## PRODUCT LINE :

- Spindles with **external drive** (i.g. belts)
- Spindles with **direct drive** (motor spindles)
  
- **synchronous motors**
- **asynchronous motors**
  
- Spindles with **ball bearings**  
(chromium steel, hybride, ...)
  
- **Grease for life lubrication**
- **Oil-air lubrication**
  
- without integrated **gearbox**
- with integrated **gearbox (up to 1:4)**
  
- Tool interface HSK, ISO, and others

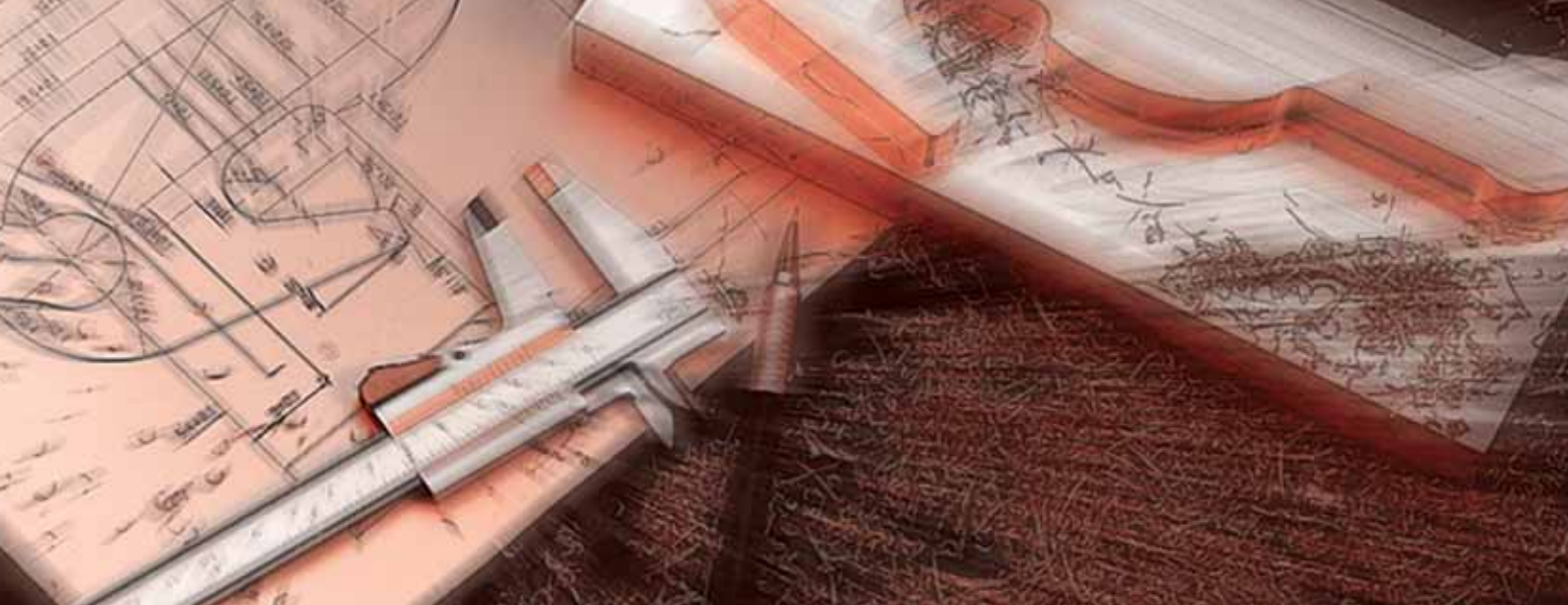

## DESIGN EXAMPLES

– BEST SELECTION –

SPINDLE NUMBER	Interface	Max. speed	Special Features
175744	ISO-40	10,000 rpm	<b>Glass/Rock cutting</b>
175431B	ISO-40	15,000 rpm	<b>Universal spindle</b>
175857	ISO-50	10,000 rpm	<b>Retrofit spindle for Aerospace application</b>
175884	HSK-E25	60,000 rpm	<b>High speed with automatic tool change</b>
175979	HSK-A32	36,000 rpm	<b>Mold &amp; Die, high speed</b>
175605	HSK-A40	30,000 rpm	<b>Mold &amp; Die with grease lubrication</b>
175782	HSK-E40	40,000 rpm	<b>Mold &amp; Die with oil air lubrication</b>
175676	HSK-E50	35,000 rpm	<b>Plug and Play Spindle, automatic spindle change</b>
175976	HSK-A63	10,000 rpm	<b>Vibration pick-up and self-retaining clamping set</b>
175553B	HSK-A63	15,000 rpm	<b>Aluminium machining, minimal spindle, growth</b>
175442B	HSK-A63	18,000 rpm	<b>Body diameter 150 mm, Automotive application</b>
175675	HSK-A63	24,000 rpm	<b>Plug and Play Spindle, automatic spindle change</b>
800022	HSK-A63	30,000 rpm	<b>80 kW at S1-100%</b>
800012A	HSK-A63	30,000 rpm	<b>100 kW at S1-100%</b>
800011	HSK-A100	6,000 rpm	<b>Spindle with integrated gearbox (2,160 Nm)</b>
175573	HSK-A100	10,000 rpm	<b>Plug and Play Spindle, automatic spindle change</b>
175460C	HSK-A100	15,000 rpm	<b>High speed and high torque spindle</b>
800029	HSK-A100	22,000 rpm	<b>130 kW at S1-100%</b>

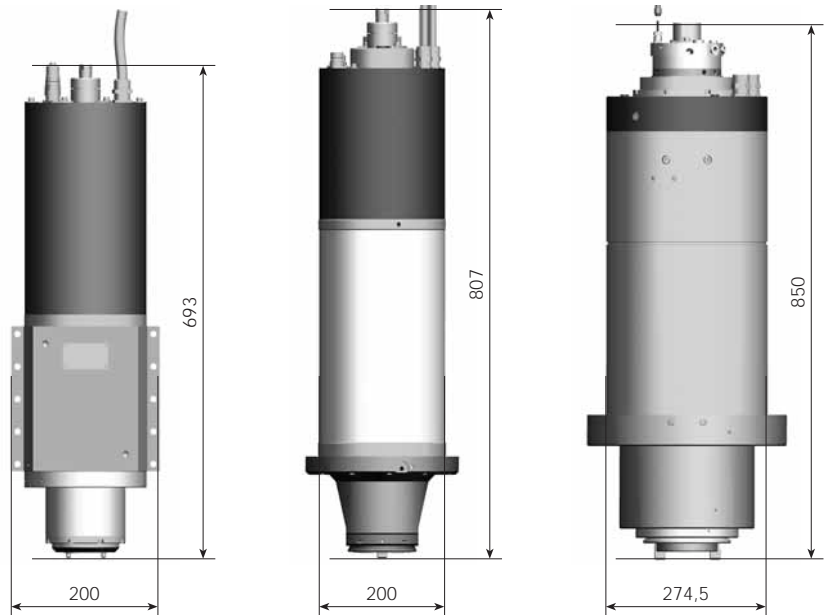

**A detailed data sheet for all spindle numbers can be downloaded from our homepage at: [www.weissgmbh.de](http://www.weissgmbh.de)**

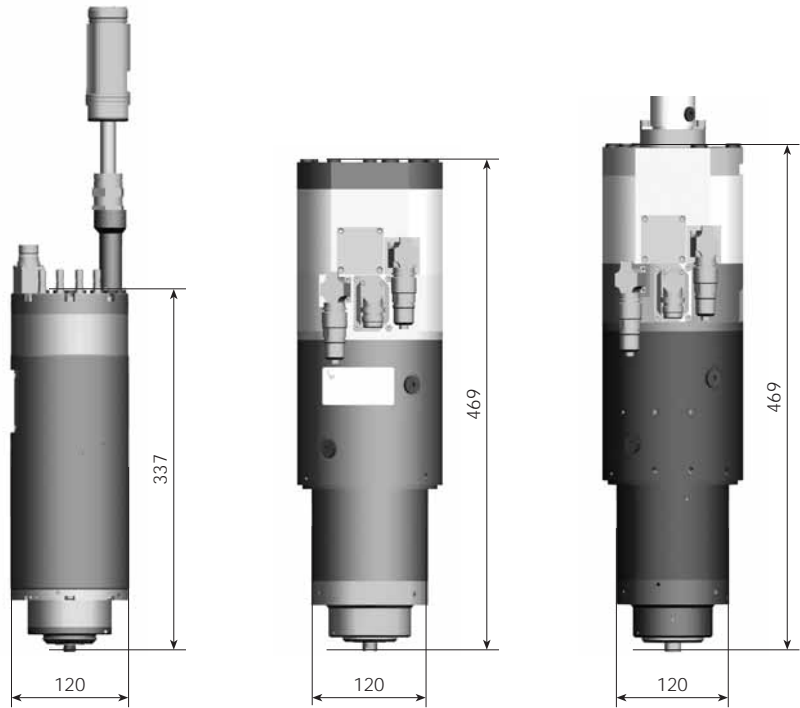

SPINDLE NUMBER	175744	175431B	175857
<b>Category:</b>	<b>Milling I Individual</b>	<b>Milling I Individual</b>	<b>Milling I Individual</b>
Tool interface:	ISO 40	ISO 40	ISO 50
Max speed:	10,000 rpm	15,000 rpm	10,000 rpm
Rated speed:	6,100 rpm	3,000 rpm	5,300 rpm
Rated power (S1-100%):	16 kW	26 kW	75 kW
Nominal torque (S1-100%):	25 Nm	84 Nm	135 Nm
Unclamp unit:	pneumatic	hydraulic	hydraulic
Motor:	synchronous	synchronous	synchronous
Moment of inertia (spindle):	0.021 kgm <sup>2</sup>	0.024 kgm <sup>2</sup>	0.09 kgm <sup>2</sup>
Housing shape:	block	cylindrical	cylindrical
Block dimensions / diameter:	200 mm	200 mm	274.5 mm
Overall length:	693 mm	807 mm	850 mm
Operating position:	vertical / nose down	vertical / nose down	horizontal / vertical
Bearing bore diameter:	70 mm	70 mm	110 mm
Bearing lubrication:	grease	grease	grease
	<p><b>Glass/ Rock cutting</b></p>	<p><b>Universal spindle</b></p>	<p><b>Retrofit spindle for Aerospace application</b></p>

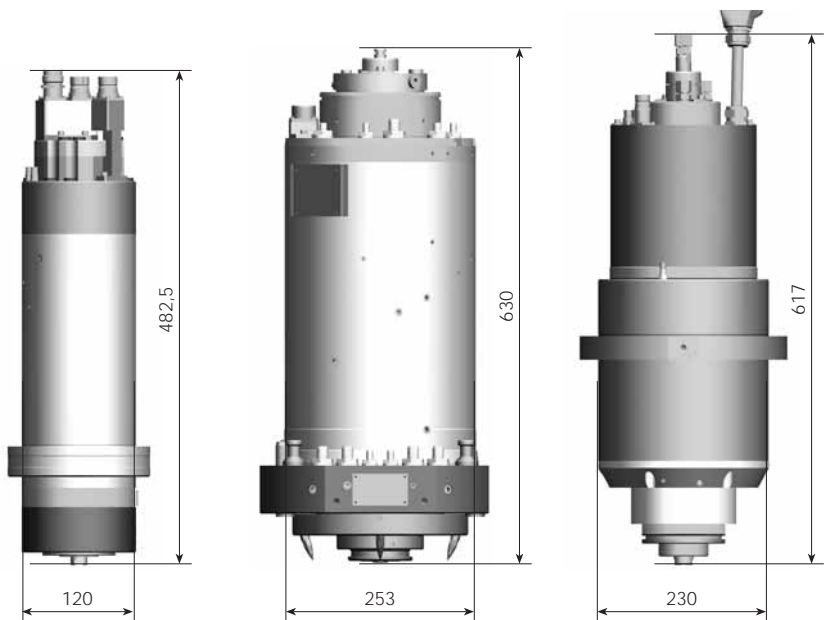

SPINDLE NUMBER	175884	175979	175605
<b>Category:</b>	<b>Milling I Individual</b>	<b>Milling I Individual</b>	<b>Milling I Individual</b>
Tool interface:	HSK-E25	HSK-A32	HSK-A40
Max speed:	60,000 rpm	36,000 rpm	30,000 rpm
Rated speed:	39,500 rpm	11,660 rpm	10,300 rpm
Rated power (S1-100%):	10 kW	7 kW	7 kW
Nominal torque (S1-100%):	2 Nm	6 Nm	6 Nm
Unclamp unit:	hydraulic	pneumatic	pneumatic
Motor:	asynchronous	asynchronous	synchronous
Moment of inertia (spindle):	0.00085 kgm <sup>2</sup>	0.003 kgm <sup>2</sup>	0.003 kgm <sup>2</sup>
Housing shape:	cylindrical	cylindrical	cylindrical
Block dimensions / diameter:	120 mm	120 mm	120 mm
Overall length:	337 mm	469 mm	469 mm
Operating position:	vertical / nose down	swivelling	swivelling
Bearing bore diameter:	30 mm	35 mm	45 mm
Bearing lubrication:	Oil-air	grease	grease
	<div style="display: flex; align-items: center;"> <div style="width: 10px; height: 10px; background-color: #444; margin-right: 5px;"></div> <div style="font-weight: bold; font-size: 0.9em;">High speed with automatic tool change</div> </div>	<div style="display: flex; align-items: center;"> <div style="width: 10px; height: 10px; background-color: #444; margin-right: 5px;"></div> <div style="font-weight: bold; font-size: 0.9em;">Mold &amp; Die, high speed</div> </div>	<div style="display: flex; align-items: center;"> <div style="width: 10px; height: 10px; background-color: #444; margin-right: 5px;"></div> <div style="font-weight: bold; font-size: 0.9em;">Mold &amp; Die with grease lubrication</div> </div>



SPINDLE NUMBER	175782	175676	175976
<b>Category:</b>	<b>Milling I Individual</b>	<b>Milling I Individual</b>	<b>Milling I Individual</b>
Tool interface:	HSK-E40	HSK-E50	HSK-A63
Max speed:	40,000 rpm	35,000 rpm	10,000 rpm
Rated speed:	20,700 rpm	7,100 rpm	2,700 rpm
Rated power (S1-100%):	13 kW	20 kW	12 kW
Nominal torque (S1-100%):	6 Nm	28 Nm	42 Nm
Unclamp unit:	hydraulic	hydraulic	hydraulic
Motor:	asynchronous	synchronous	synchronous
Moment of inertia (spindle):	0.003 kgm <sup>2</sup>	0.008 kgm <sup>2</sup>	0.015 kgm <sup>2</sup>
Housing shape:	cylindrical	cylindrical	cylindrical
Block dimensions / diameter:	120 mm	253 mm	230 mm
Overall length:	482.5 mm	630 mm	617 mm
Operating position:	horizontal	swivelling	horizontal / vertical
Bearing bore diameter:	45 mm	50 mm	70 mm
Bearing lubrication:	Oil-air	Oil-air	grease
<ul style="list-style-type: none"> <li>■ <b>Mold &amp; Die with oil air lubrication</b></li> </ul>	<ul style="list-style-type: none"> <li>■ <b>Plug and Play for automatic spindle changes</b></li> </ul>	<ul style="list-style-type: none"> <li>■ <b>With vibration pick-up</b></li> </ul>	

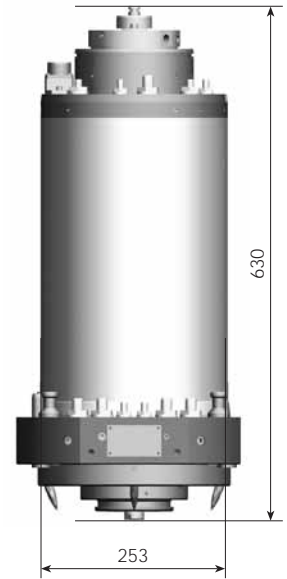
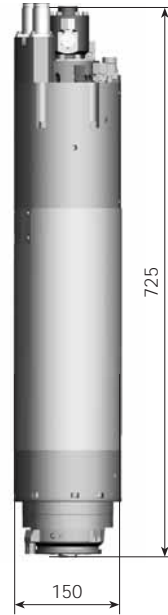

SPINDLE NUMBER	175553B	175442B	175675
<b>Category:</b>	<b>Milling I Individual</b>	<b>Milling I Individual</b>	<b>Milling I Individual</b>
Tool interface:	HSK-A63	HSK-A63	HSK-A63
Max speed:	15,000 rpm	18,000 rpm	24,000 rpm
Rated speed:	1,130 rpm	8,000 rpm	5,000 rpm
Rated power (S1-100%):	19 kW	29 kW	50 kW
Nominal torque (S1-100%):	161 Nm	35 Nm	95 Nm
Unclamp unit:	hydraulic	hydraulic	hydraulic
Motor:	asynchronous	synchronous	synchronous
Moment of inertia (spindle):	0.097 kgm <sup>2</sup>	0.011 kgm <sup>2</sup>	0.041 kgm <sup>2</sup>
Housing shape:	cylindrical	cylindrical	cylindrical
Block dimensions / diameter:	240 mm	150 mm	253 mm
Overall length:	1030 mm	725 mm	630 mm
Operating position:	horizontal	horizontal	swivelling
Bearing bore diameter:	70 mm	70 mm	70 mm
Bearing lubrication:	grease	grease	Oil-air
	<p><b>Aluminium machining, minimal spindle, growth</b></p>	<p><b>Body diameter 150 mm, Automotive application</b></p>	<p><b>Plug and Play Spindle, automatic spindle changes</b></p>

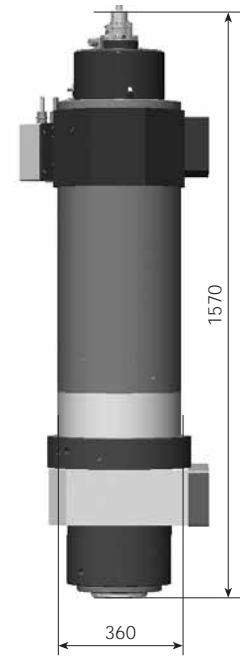
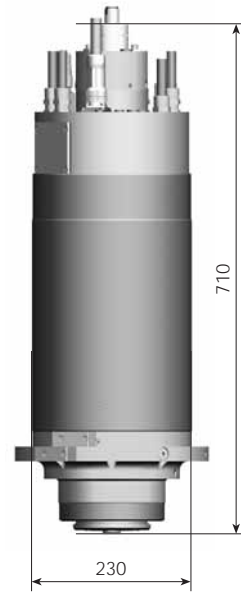
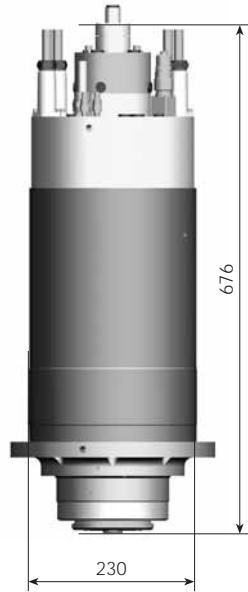

SPINDLE NUMBER	800022	800012A	800011
<b>Category:</b>	<b>Milling I Individual</b>	<b>Milling I Individual</b>	<b>Milling I Individual</b>
Tool interface:	HSK-A63	HSK-A63	HSK-A100
Max speed:	30,000 rpm	30,000 rpm	6,000 rpm
Rated speed:	16,500 rpm	16,500 rpm	1.300 rpm
Rated power (S1-100%):	80 kW	100 kW	80 kW
Nominal torque (S1-100%):	26 Nm	58 Nm	2.160 Nm bei 1:4
Unclamp unit:	hydraulic	hydraulic	hydraulic
Motor:	asynchronous	synchronous	synchronous
Moment of inertia (spindle):	0.028 kgm <sup>2</sup>	0.032 kgm <sup>2</sup>	0,070 kgm <sup>2</sup>
Housing shape:	cylindrical	cylindrical	cylindrical
Block dimensions / diameter:	230 mm	230 mm	420 mm
Overall length:	676 mm	710 mm	1,570 mm
Operating position:	horizontal	swivelling	vertical / nose down
Bearing bore diameter:	70 mm	70 mm	130 mm
Bearing lubrication:	Oil-air	Oil-air	grease
	<b>80 kW</b> at S1 – S100%	<b>100 kW</b> at S1 – S100%	<b>Plug and Play</b> Spindle, automatic spindle changes



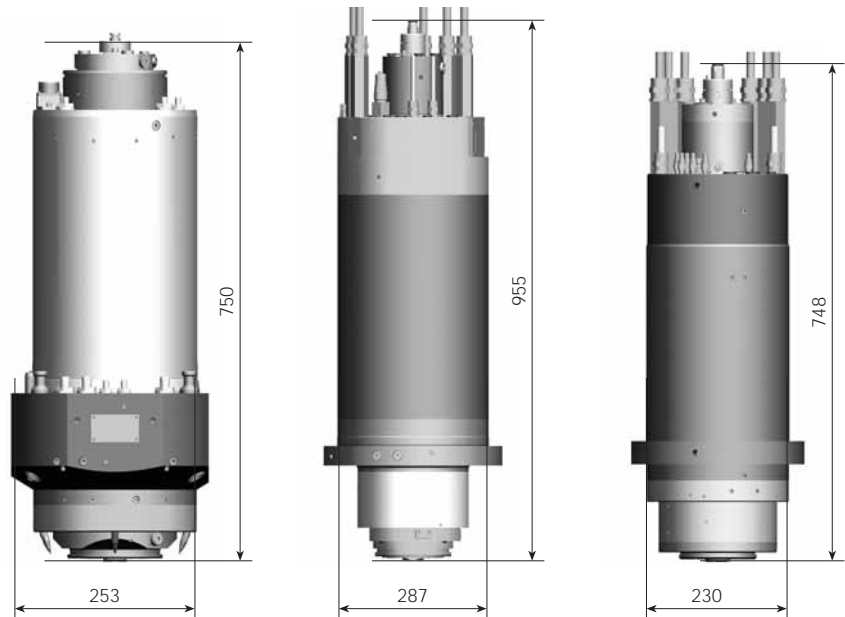

SPINDLE NUMBER	175573	175460C	800029
<b>Category:</b>	<b>Milling I Individual</b>	<b>Milling I Individual</b>	<b>Milling I Individual</b>
Tool interface:	HSK-A100	HSK-A100	HSK-A100
Max speed:	10,000 rpm	15,000 rpm	22,000 rpm
Rated speed:	2,300 rpm	2,000 rpm	17,000 rpm
Rated power (S1-100%):	41 kW	32 kW	130 kW
Nominal torque (S1-100%):	200 Nm	300 Nm	73 Nm
Unclamp unit:	hydraulic	hydraulic	hydraulic
Motor:	synchronous	asynchronous	synchronous
Moment of inertia (spindle):	0.09 kgm <sup>2</sup>	0.26 kgm <sup>2</sup>	0.05 kgm <sup>2</sup>
Housing shape:	cylindrical	cylindrical	cylindrical
Block dimensions / diameter:	253 mm	287 mm	230 mm
Overall length:	750 mm	955 mm	748 mm
Operating position:	swivelling	vertical / nose down	swivelling
Bearing bore diameter:	110 mm	110 mm	100 mm
Bearing lubrication:	grease	Oil-air	Oil-air
	<b>Plug and Play Spindle, automatic spindle changes</b>	<b>High speed and high torque spindle</b>	<b>100 kW at S1 - S100%</b>

# YOUR CONTACT

## Siemens and WEISS – everywhere near by!

The Siemens Automation & Drives division is present around the world through its branches – near you as well! Qualified and competent contact partners stand ready to work at your side, on site, and provide support.

WEISS Spindeltechnologie GmbH and its 6 current service centres in 4 continents serve as the centre of competence for Siemens in all questions related to spindle technology. Almost on 300 employees are currently employed for all spindle-related questions, from development to production to service.

We would gladly help you find answers to any questions you might have: whether you are interested in more brochures, have specific questions, or are ready to enquire about a detailed offer. **We'll help you to the next step, quickly and simply.**

If you already know your personal contact partner at Siemens or WEISS, you may contact them immediately regarding your enquiry.

We also recommend the following alternative options for initiating contact with us:

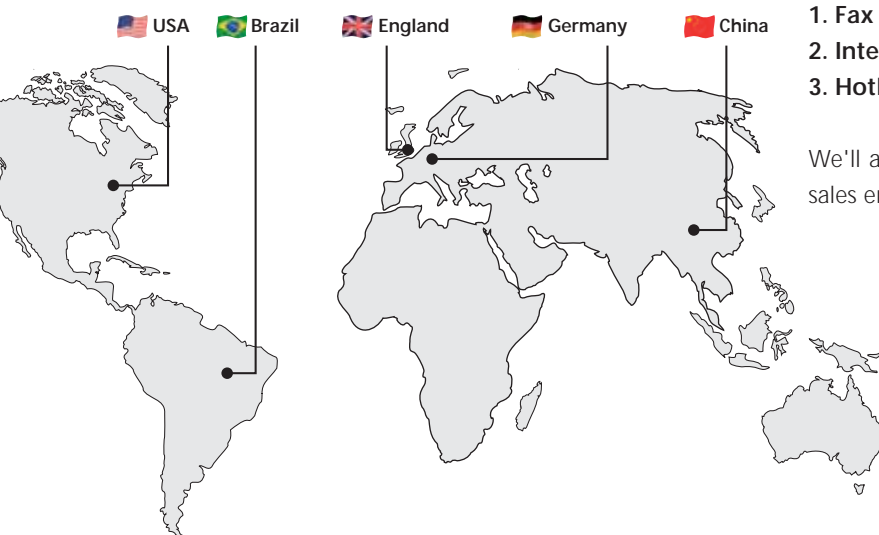

1. Fax enquiry form (see right)
2. Internet enquiry: [www.weissgmbh.de/kontakt](http://www.weissgmbh.de/kontakt)
3. Hotline: +49-9721-7701-0

We'll automatically forward your enquiry to the appropriate sales employee who will contact you immediately, as desired.

**+ 49 (0) 9721 / 7701 - 133**

WEISS Spindeltechnologie GmbH  
A Siemens Company

Central fax number. Your enquiry will be automatically forwarded to your personal contact.

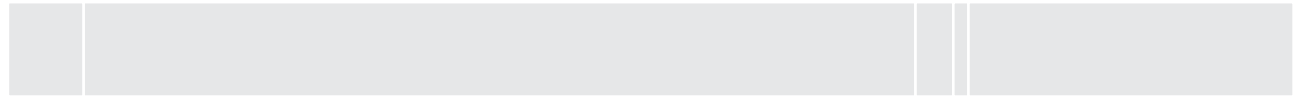

## ENQUIRY FORM

Company

---

Contact

---

Address

---

Country

---

Telephone

---

Fax

---

E-Mail

---

Please send me the following information:

- WEISS – The Company** (Brochure) – available June 2006
- WEISS – The Company** (Film) – available October 2005
  
- GSS – Global Spindle Solutions** (Overview – Product catalogue)
- SWSS – Siemens WEISS Spindle Services** (Overview – Service catalogue)
  
- Product catalogue **TURNING**
- Product catalogue **MILLING**
- Product catalogue **GRINDING**
- Product catalogue **SPECIAL APPLICATIONS** – available March 2006
- Product catalogue **HEAVY DUTY CUTTING** – available March 2006

- Language **GERMAN**
- Language **ENGLISH**

Please phone me back regarding ...

---

---

---

**Germany**

Weiss Spindeltechnologie GmbH

**Head Office/Sales**

Rudolf-Diesel-Str. 35  
97424 Schweinfurt

Phone: +49 (0) 9721 7701-0

Fax: +49 (0) 9721 7701-133

**SWSS**

Birkenfelder Weg 14

96126 Maroldsweisach

Phone: +49 (0) 9532 9229 347

Fax: +49 (0) 9532 9229 377

e-mail: [info@weissgmbh.de](mailto:info@weissgmbh.de)

[www.weissgmbh.de](http://www.weissgmbh.de)

**United Kingdom**

Siemens Weiss Spindle Service  
Unit 3 A, Brooke Park, Handforth  
Dean, Cheshire, SK9 3PR,  
Manchester

Phone: +44 1625 548 840

Fax: +44 1625 543 488

e-mail:

[spindle.service@siemens.com](mailto:spindle.service@siemens.com)

**USA**

Weiss Spindle Technology, Inc  
7255 Industrial Park Blvd. /Unit K  
Mentor, OH 44060

Phone: +1 440 946 4003

Fax: +1 440 942 9056

**Brazil**

Siemens Ltda.

Rua Cel. Bento Bicudo, 111

05069-900 Lapa

São Paulo

Phone: +55 11 3833 4435

Fax: +55 11 3833 4434

**China**

Siemens Factory Automation  
Engineering Ltd.

Service Department

No. 7 Jing Shun Road

Beijing

Postcode: 100028

Phone: +86 10 64719990

Fax: +86 10 64719991

**WEISS**

G M B H

**WEISS Spindeltechnologie GmbH**  
A Siemens Company